

LAZER Z[®] LPG MODELS

**For Serial Nos.
850,000 & Higher
Lazer Z (LP Units)**
Part No. 4500-645 Rev. A

Operator's Manual

Important: The engine in this product is not equipped with a spark arrester muffler. It is a violation of California Public Resource Code (CPRC) Section 4442 to use or operate this engine on any forest-covered, brush-covered, or grass-covered land as defined in CPRC 4126. Other states or federal areas may have similar laws.

To acquire a spark arrester for your unit, see your Engine Service Dealer.

This spark ignition system complies with Canadian ICES-002 Ce système d'allumage par étincelle de véhicule est conforme à la norme NMB-002 du Canada.

The enclosed Engine Owner's Manual is supplied for information regarding The U.S. Environmental Protection Agency (EPA) and the California Emission Control Regulation of emission systems, maintenance and warranty.

Keep this engine Owner's Manual with your unit. Should this engine Owner's Manual become damaged or illegible, replace immediately. Replacements may be ordered through the engine manufacturer.

Exmark reserves the right to make changes or add improvements to its products at any time without incurring any obligation to make such changes to products manufactured previously. Exmark, or its distributors and dealers, accept no responsibility for variations which may be evident in the actual specifications of its products and the statements and descriptions contained in this publication.



EXMARK PARTS PLUS
PARTS
OVERNIGHT
OR FREE*

If your Exmark dealer does not have the Exmark part in stock, Exmark will get the parts to the dealer the next business day or the part will be FREE Guaranteed!! (Some restrictions apply. See your participating Exmark Dealer for details.)

Introduction

CONGRATULATIONS on the purchase of your Exmark Mower. This product has been carefully designed and manufactured to give you a maximum amount of dependability and years of trouble-free operation.

This manual contains operating, maintenance, adjustment, and safety instructions for your Exmark mower.

BEFORE OPERATING YOUR MOWER, CAREFULLY READ THIS MANUAL IN ITS ENTIRETY.

By following the operating, maintenance, and safety instructions, you will prolong the life of your mower, maintain its maximum efficiency, and promote safe operation.

If additional information is needed, or should you require trained mechanic service, contact your authorized Exmark equipment dealer or distributor. Exmark parts manuals are available online at <http://www.exmark.com/manuals.htm>

All Exmark equipment dealers and distributors are kept informed of the latest methods of servicing and are equipped to provide prompt and efficient service in the field or at their service stations. They carry ample stock of service parts or can secure them promptly for you from the factory.

All Exmark parts are thoroughly tested and inspected before leaving the factory, however, attention is required on your part if you are to obtain the fullest measure of satisfaction and performance.

Whenever you need service, genuine Exmark parts, or additional information, contact an Authorized Service Dealer or Exmark Customer Service and have the model and serial numbers of your product ready.

Figure 1 identifies the location of the model and serial numbers on the product. Write the numbers in the space provided.

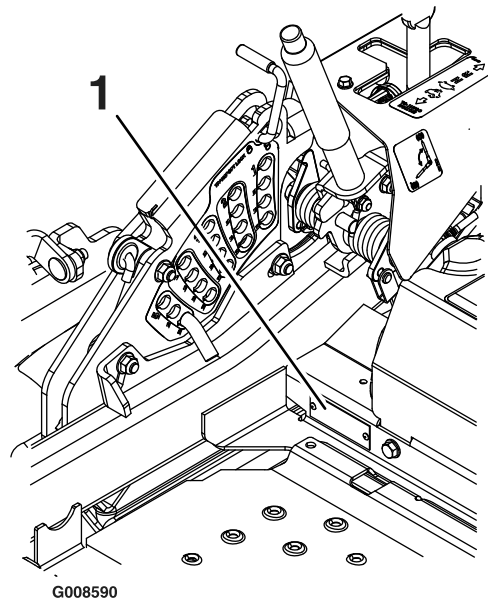

Figure 1

1. Model and serial number location

Model No. _____
Serial No. _____

Contents

Introduction	3	Adjusting the Parking Brake.....	45
Safety	5	Electric Clutch Adjustment.....	46
Safety Alert Symbol.....	5	Motion Control Linkage Adjustment	48
Safe Operating Practices	5	Motion Control Damper Adjustment.....	49
Safety and Instructional Decals	13	Motion Control Neutral Lock Pivot Adjustment	49
Specifications	18	Motion Control Handle Adjustment	49
Model Numbers	18	Motion Control Full Forward Tracking Adjustment	50
Systems	18	Caster Pivot Bearings Pre-Load Adjustment	50
Dimensions.....	20	Cleaning	51
Torque Requirements	22	Clean Engine and Exhaust System Area	51
Product Overview	22	Remove Engine Shrouds and Clean Cooling Fins.....	51
Operation	23	Clean Hydro Fan Cooling Fins	51
Controls.....	23	Clean Debris From Machine	51
Pre-Start.....	26	Clean Grass Build-Up Under Deck	51
Operating Instructions	26	Waste Disposal.....	52
Transporting	30	Troubleshooting	53
Maintenance	33	Schematics	56
Recommended Maintenance Schedule(s)	33		
Periodic Maintenance	34		
Check Engine Oil Level	34		
Check Mower Blades	36		
Check Safety Interlock System	37		
Check Rollover Protections Systems (Roll Bar) Knobs.....	37		
Check Seat Belt.....	38		
Check for Loose Hardware	38		
Service Air Cleaner	38		
Change Engine Oil.....	38		
Check Hydraulic Oil Level	38		
Check Tire Pressures	39		
Check Condition Of Belts.....	39		
Lubricate Grease Fittings.....	39		
Lubricate Brake Handle Pivot	40		
Lubricate Deck Lift Pivot.....	40		
Check Spark Plugs	40		
Check LPG Tank.....	40		
Check LPG Fuel Delivery System	40		
Change Hydraulic System Filter and Fluid	41		
Wheel Hub - Slotted Nut Torque Specification.....	42		
Thread Locking Adhesives.....	42		
Copper-Based Anti-seize	42		
Dielectric Grease.....	42		
LPG Regulator	42		
Adjustments	43		
Deck Leveling	43		
Pump Drive Belt Tension.....	44		
Deck Belt Tension	45		

Safety

Safety Alert Symbol

This Safety Alert Symbol (Figure 2) is used both in this manual and on the machine to identify important safety messages which must be followed to avoid accidents.

This symbol means: **ATTENTION! BECOME ALERT! YOUR SAFETY IS INVOLVED!**



Figure 2

1. Safety alert symbol

The safety alert symbol appears above information which alerts you to unsafe actions or situations and will be followed by the word **DANGER**, **WARNING**, or **CAUTION**.

DANGER: White lettering / Red background. Indicates an imminently hazardous situation which, if not avoided, **Will** result in death or serious injury.

WARNING: Black lettering / Orange background. Indicates a potentially hazardous situation which, if not avoided, **Could** result in death or serious injury.

CAUTION: Black lettering / Yellow background. Indicates a potentially hazardous situation which, if not avoided, **May** result in minor or moderate injury.

This manual uses two other words to highlight information. **Important** calls attention to special mechanical information and **Note** emphasizes general information worthy of special attention.

Safe Operating Practices

Training

What is LPG? LPG stands for liquefied petroleum gas and is more commonly called propane. LPG is a liquid fuel that is stored in a tank under pressure. Before the liquid leaves the tank, it is converted into a vapor. Since LPG is stored as both liquid and gas, it may leak from joints or connections that are not sealed properly. LPG becomes flammable when it is mixed with air.

The LPG information in this Operator's manual is provided only as a guide. Consult the NFPA 58: Liquefied Petroleum Gas Code, 2008 Edition for additional safety information. This National Fire Protection Association (NFPA) code pertains to the handling, storing, transporting, and usage of LPG.

- Read the Operator's Manual and other training material. If the operator(s) or mechanic(s) can not read English it is the owner's responsibility to explain this material to them.
- Become familiar with the safe operation of the equipment, operator controls, and safety signs.
- All operators and mechanics should be trained. The owner is responsible for training the users.
- Never let children or untrained people operate or service the equipment. Local regulations may restrict the age of the operator.
- Only adults and mature teenagers should operate a mower, and even mature teenagers should have adult supervision. Be sure a teenager:
 1. has read and understands the Operator's Manual and recognizes the risks involved;
 2. is sufficiently mature to use caution; and
 3. is of sufficient size and weight to operate the controls comfortably and to manage the mower without taking risks.
- The owner/user can prevent and is responsible for accidents or injuries occurring to himself or herself, other people or property.

Preparation

- Evaluate the terrain to determine what accessories and attachments are needed to properly and safely perform the job. Only use accessories and attachments approved by Exmark.
- Wear appropriate clothing including safety glasses, substantial footwear, long trousers, and hearing protection. Do Not operate when barefoot or when wearing open sandals. Long hair, loose clothing or jewelry may get tangled in moving parts.

⚠ CAUTION

This machine produces sound levels in excess of 85 dBA at the operator's ear and can cause hearing loss through extended periods of exposure.

Wear hearing protection when operating this machine.

- Inspect the area where the equipment is to be used and remove all rocks, toys, sticks, wires, bones, and other foreign objects which can be thrown by the machine and may cause personal injury to the operator or bystanders.

⚠ DANGER

LPG fuel is extremely flammable and vapors are explosive.

A fire or explosion from LPG fuel can burn you, others, and cause property damage.

- Never smoke around tank(s) and stay away from an open flame or where fumes may be ignited by a spark.
- Extinguish all sources of spark or flame when approaching LPG tanks or mowers. The hazard increases for enclosed trailers or storage locations where vapor leakage may occur and collect.
- LPG is heavier than air and may accumulate in low lying areas, such as ditches, drains, or pits.
- LPG tank(s) should be filled by trained and qualified personnel ONLY.
- Never tamper with or repair the tank(s); contact trained and qualified personnel.
- Do Not change the tank(s) when the engine is running.
- Before disconnecting the hose(s), purge all LPG vapors from the system, by closing the fuel valve(s) on ALL tanks and allowing the engine to run until it stops.
- Store the tank(s) away from heat, sparks, or open flames.
- Do Not operate without entire exhaust system in place and in proper working condition.

⚠ DANGER

LPG fuel is extremely flammable and vapors are explosive.

- In case of fire take the following steps:
 1. If you can safely do so, stop the flow of gas as quickly as possible. Never put out flame unless gas can be shut off.
 2. Notify the Fire Department and clear immediate area of all people.
 3. When gas flow is stopped, put out the fire. Usually when flow of gas is cutoff, fire will automatically stop.
 4. If gas flow cannot be immediately stopped, direct water on tanks to keep them cool, but Do Not put out fire.
- Storage locations and trailers should be equipped with at least one approved portable fire extinguisher having a minimum capacity of 18 lb (8.2 kg) dry chemical with a B:C rating. Do Not use Carbon Tetrachloride extinguishers (Pyrene etc.).

⚠ DANGER

LPG vapors and liquid escaping from the tank may cause serious injury or death. Vapors or liquid may cause suffocation, freezing of tissue, or frostbite.

- Store and service the mower in a well ventilated area.
- An approved LPG detector installed in trailers and storage areas is recommended.
- LPG is heavier than air and may accumulate in low lying areas, such as ditches, drains, or pits.
- Avoid breathing of vapors.
- Keep away from vent valve.
- Keep away from eyes and skin.
- Contact trained and qualified personnel if tank shows signs of frosted areas, makes a hissing sound, or emits a foul odor.
- Obtain immediate medical attention if contact occurs with vapors or liquid.

- Check that the operator's presence controls, safety switches, and shields are attached and functioning properly. Do Not operate unless they are functioning properly.

Inspection

It is very important to check the LPG tank and components for wear or leaks.

Important: Never check for leaks using an open flame.

Important: Never use bare hands when checking the fitting or valve. Escaping LPG vapor and liquid freezes skin on contact.

Important: Only hand tighten tank connection fitting. Over tightening by the use of tools may cause damage. If hand tightening does not stop a leak, contact trained and qualified personnel immediately.

- Before each use:
 - Visually inspect the tank, hose, and fitting and be alert to a foul odor coming from the tank.

Safety

- The LPG tank should be free of dents or damage. If the tank show signs of dents or damage, replace it immediately.
- Check the valve and fitting openings for dirt and debris.
- Slowly open the valve all the way and listen for a continuous hiss from the regulator, it may indicate a leak.
- LPG has a rotten egg or skunk smell added to it to help detect a gas leak. If you detect a gas leak:
 - ◇ Turn off the LPG valve if you can safely do so.
 - ◇ Leave the area.
 - ◇ Contact trained and qualified personnel immediately.
- Do Not use if the hoses are abraded, damaged, kinked, or flattened.
- Make sure the tank is securely mounted to the mower. If the tank is loose, the hose or fittings may leak.
- **With each tank change:**
 - Check all gauges, fittings, and valves for damage.
 - Look for deterioration, damaged or missing o-rings on tank connection fitting.
 - Inspect the LPG tank and the fuel connection joint for leaks. Use the following procedure below to detect leaks:
 - ◇ Apply an approved leak detector solution, obtained from a trained and qualified LPG distributor, or a thick non-ammonia soapy water solution (50% non-ammonia soap and 50% water). (A leak detector solution that contains ammonia will cause the fittings to corrode and leak.)
 - ◇ Using a small brush or spray bottle, apply the solution around all the fittings of the LPG tank and the fuel connection joint.
 - ◇ Slowly open the gas valve a half-turn.
 - ◇ If bubbles are detected, the joint or fitting has a leak. Shut off the valve, tighten the leaking connection, and slowly open the valve again. If bubbles still appear, Do Not use the tank. If it is safe to do so, remove the tank from your mower; otherwise, contact trained and qualified personnel immediately.
 - ◇ If no bubbles are detected, the LPG tank may be used.
- **Weekly:**
 - Check the entire LPG fuel delivery system for damage or deterioration.
 - Check the entire LPG fuel delivery system for leaks at all joints using the same method as described in the previous section.
 - Follow all the inspection checks as specified in the two previous inspection sections.
- **Tank Requalification:**
 - USDOT (United States Department of Transportation) regulations require LPG tanks to be inspected, requalified, and marked within 12 years of the manufacture date and on a regular basis thereafter. Typically this occurs when the tank is refilled; contact a trained and qualified LPG tank provider for more details.
 - Do Not fill the LPG tank if it is beyond the requalification period.
 - Do Not fill damaged or rusted LPG tanks.

Operation

⚠ WARNING

Operating engine parts, especially the muffler, become extremely hot. Severe burns can occur on contact and debris, such as leaves, grass, brush, etc. can catch fire.

- **Allow engine parts, especially the muffler, to cool before touching.**
- **Remove accumulated debris from muffler and engine area.**
- **Install and maintain in working order a spark arrester before using equipment on forest-covered, grass-covered, or brush-covered unimproved land.**

WARNING

Engine exhaust contains carbon monoxide, which is an odorless deadly poison that can kill you.

Do Not run engine indoors or in a small confined area where dangerous carbon monoxide fumes can collect.

- Operate only in daylight or good artificial light, keeping away from holes and hidden hazards.
- Be sure all drives are in neutral and parking brake is engaged before starting engine. Use seat belts with the roll bar in the raised and locked position.
- Never operate the mower with damaged guards, shields, or covers. Always have safety shields, guards, switches and other devices in place and in proper working condition.
- Never mow with the discharge deflector raised, removed or altered unless there is a grass collection system or mulch kit in place and working properly.
- Do Not change the engine governor setting or overspeed the engine.
- Stop engine, wait for all moving parts to stop, remove key and engage parking brake:
 - Before checking, cleaning or working on the mower.
 - After striking a foreign object or abnormal vibration occurs (inspect the mower for damage and make repairs before restarting and operating the mower).
 - Before clearing blockages.
 - Whenever you leave the mower.
- Stop engine, wait for all moving parts to stop, and engage parking brake:
 - Before changing tanks.
 - Before dumping the grass catcher.

WARNING

Hands, feet, hair, clothing, or accessories can become entangled in rotating parts. Contact with the rotating parts can cause traumatic amputation or severe lacerations.

- **Do Not operate the machine without guards, shields, and safety devices in place and working properly.**
- **Keep hands, feet, hair, jewelry, or clothing away from rotating parts.**
- **NEVER** carry passengers. **DO NOT** operate the mower when people, especially children, or pets are in the area.
- Be alert, slow down and use caution when making turns. Look behind and to the side before changing directions.
- Stop the blades, slow down, and use caution when crossing surfaces other than grass and when transporting the mower to and from the area to be mowed.
- Be aware of the mower discharge path and direct discharge away from others.
- Do Not operate the mower under the influence of alcohol or drugs.
- Use extreme care when loading or unloading the machine into a trailer or truck.
- Use care when approaching blind corners, shrubs, trees, or other objects that may obscure vision.

Slope Operation

Use **Extreme** caution when mowing and/or turning on slopes as loss of traction and/or tip-over could occur. The operator is responsible for safe operation on slopes.

⚠ DANGER

Operating on wet grass or steep slopes can cause sliding and loss of control. Wheels dropping over edges, ditches, steep banks, or water can cause rollovers, which may result in serious injury, death or drowning.

- Do Not mow slopes when grass is wet.
- Do Not mow near drop-offs or near water.
- Do Not mow slopes greater than 15 degrees.
- Reduce speed and use extreme caution on slopes.
- Avoid sudden turns or rapid speed changes.
- Keep the roll bar in the raised and locked position and use seat belt.

- See inside the back cover to determine the approximate slope angle of the area to be mowed.
- Use a walk behind mower and/or a hand trimmer near drop-offs, ditches, steep banks or water. (Figure 3).

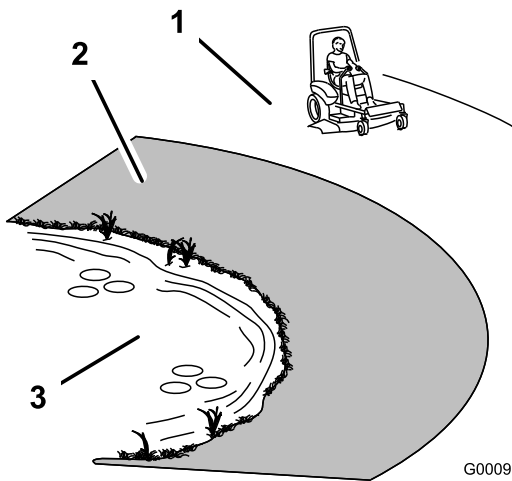

Figure 3

1. Safe Zone-Use the mower here on slopes less than 15 degrees
2. Danger Zone-Use a walk behind mower and/or hand trimmer on slopes greater than 15 degrees, near drop-offs and water.
3. Water

- Remove or mark obstacles such as rocks, tree limbs, etc. from the mowing area. Tall grass can hide obstacles.

- Watch for ditches, holes, rocks, dips and rises that change the operating angle, as rough terrain could overturn the machine.
- Avoid sudden starts when mowing uphill because the mower may tip backwards.
- Be aware that operating on wet grass, across steep slopes or down hill may cause the mower to lose traction. Loss of traction to the drive wheels may result in sliding and loss of braking and steering.
- Always avoid sudden starting or stopping on a slope. If tires lose traction, disengage the blades and proceed slowly off the slope.
- Follow the manufacturer's recommendations for wheel weights or counter weights to improve stability.
- Use extreme care with grass catchers or attachments. These can change the stability of the machine and cause loss of control.

Using the Rollover Protection System (ROPS)

A Rollover Protection System (roll bar) is installed on the unit.

⚠ WARNING

There is no rollover protection when the roll bar is down. Wheels dropping over edges, ditches, steep banks, or water can cause rollovers, which may result in serious injury, death or drowning.

- Keep the roll bar in the raised and locked position and use seat belt.
 - Lower the roll bar only when absolutely necessary.
 - Do Not wear seat belt when the roll bar is down.
 - Drive slowly and carefully.
 - Raise the roll bar as soon as clearance permits.
- Check carefully for overhead clearances (i.e. branches, doorways, and electrical wires) before

driving under any objects and Do Not contact them.

- In the event of a rollover, take the unit to an Authorized Service Dealer to have the ROPS inspected.

Maintenance and Storage

- Disengage drives, lower implement, set parking brake, stop engine and remove key or disconnect spark plug wire. Wait for all movement to stop before adjusting, cleaning or repairing.
- Keep engine and engine area free from accumulation of grass, leaves, excessive grease or oil, and other debris which can accumulate in these areas. These materials can become combustible and may result in a fire.
- Let engine cool before storing and Do Not store near flame or any enclosed area where open pilot lights or heat appliances are present.
- Store mower in a well ventilated outdoor shelter, building, or trailer.
- Close fuel valve when mower is not in use, including while storing or transporting.
- The empty tank(s) should be treated as if it was full.
- Store the tank(s) outside of buildings in an open well ventilated area, away from spark and flames.
- Do Not store the tank(s) or machine with tank(s) in an area where the temperature can rise above 120°F (49°C). If the temperature exceeds approximately 160°F (71°C), the tank will release highly flammable propane vapor. See Preparation in the Safety Section.
- Store the tank(s) in upright position or with pressure relief valve towards the top.
- Do Not drag, drop, or abuse the tank(s).
- Storage of the empty tank(s) should follow local and state regulations.
- Park machine on level ground. Never allow untrained personnel to service machine.
- Use jack stands to support components when required.
- Carefully release pressure from components with stored energy.

- Disconnect battery or remove spark plug wire before making any repairs. Disconnect the negative terminal first and the positive last. Reconnect positive first and negative last.
- Use care when checking blades. Wrap the blade(s) or wear gloves, and use caution when servicing them. Only replace damaged blades. Never straighten or weld them.
- Keep hands and feet away from moving parts. If possible, Do Not make adjustments with the engine running.
- Charge batteries in an open well ventilated area, away from spark and flames. Unplug charger before connecting or disconnecting from battery. Wear protective clothing and use insulated tools.

DANGER

Charging or jump starting the battery may produce explosive gases. Battery gases can explode causing serious injury.

- **Keep sparks, flames, or cigarettes away from battery.**
- **Ventilate when charging or using battery in an enclosed space.**
- **Make sure venting path of battery is always open once battery is filled with acid.**
- **Always shield eyes and face from battery.**

DANGER

Battery electrolyte contains sulfuric acid, which is poisonous and can cause severe burns. Swallowing electrolyte can be fatal or if it touches skin can cause severe burns.

- **Wear safety glasses to shield eyes, and rubber gloves to protect skin and clothing when handling electrolyte.**
- **Do Not swallow electrolyte.**
- **In the event of an accident, flush with water and call a doctor immediately.**

⚠ CAUTION

If the ignition is in the “ON” position there is potential for sparks and engagement of components. Sparks could cause an explosion or moving parts could accidentally engage causing personal injury.

Be sure ignition switch is in the “OFF” position before charging the battery.

- Keep all guards, shields and all safety devices in place and in safe working condition.
- Check all bolts frequently to maintain proper tightness.
- Frequently check for worn or deteriorating components that could create a hazard.

⚠ WARNING

Removing standard original equipment parts, or using non-Exmark replacement parts and accessories may alter the warranty, traction, and safety of the machine. Failure to use original Exmark parts could cause serious injury or death.

Replace all parts including, but not limited to tires, belts, and blades with original Exmark parts.

⚠ WARNING

Hydraulic fluid escaping under pressure can penetrate skin and cause injury. Fluid accidentally injected into the skin must be surgically removed within a few hours by a doctor familiar with this form of injury or gangrene may result.

- If equipped, make sure all hydraulic fluid hoses and lines are in good condition and all hydraulic connections and fittings are tight before applying pressure to hydraulic system.
- Keep body and hands away from pinhole leaks or nozzles that eject high pressure hydraulic fluid.
- Use cardboard or paper, not your hands, to find hydraulic leaks.
- Safely relieve all pressure in the hydraulic system by placing the motion control levers in neutral and shutting off the engine before performing any work on the hydraulic system.

Safety and Instructional Decals

- Keep all safety signs legible. Remove all grease, dirt and debris from safety signs and instructional labels.
- Replace all worn, damaged, or missing safety signs.
- When replacement components are installed, be sure that current safety signs are affixed to the replaced components.
- If an attachment or accessory has been installed, make sure current safety signs are visible.
- New safety signs may be obtained from your authorized Exmark equipment dealer or distributor or from Exmark Mfg. Co. Inc.
- Safety signs may be affixed by peeling off the backing to expose the adhesive surface. Apply only to a clean, dry surface. Smooth to remove any air bubbles.
- Familiarize yourself with the following safety signs and instruction labels. They are critical to the safe operation of your Exmark commercial mower.



1-303508



1-403005

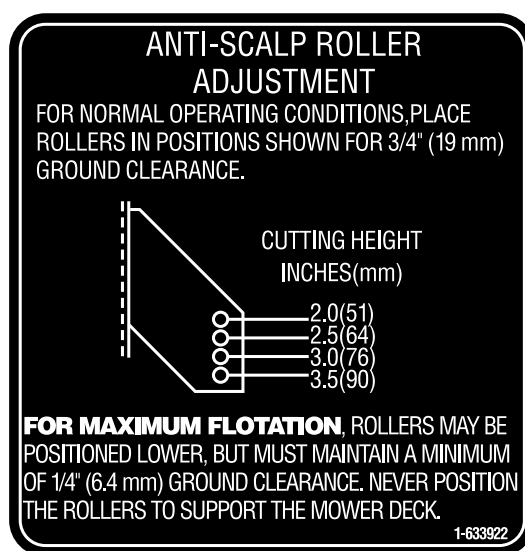

1-633922



98-5954



103-2076

⚠ WARNING



TO AVOID INJURY OR DEATH FROM ROLLOVER:
Keep roll bar in the raised and locked position and use seat belt.



THERE IS NO ROLL OVER PROTECTION WHEN THE ROLL BAR IS DOWN.
Lower the roll bar only when absolutely necessary.
Do not wear seat belt when the roll bar is down.
Drive slowly and carefully.
Raise the roll bar as soon as clearance permits.
Read and follow slope operation instructions and warnings.

107-2102

107-2102

Lubricate Blade Bolt threads with copper based antiseize or grease and torque to 55-60 ft-lbs (75-81 N·m)

109-3148

109-3148

MOTION CONTROL



109-7232

109-7232

1. Fast
2. Slow
3. Neutral
4. Reverse

⚠ WARNING

- Operating on wet grass or steep slopes can cause sliding and loss of control.
- Wheels dropping over edges can cause rollovers, which may result in serious injury, death or drowning.
- To avoid loss of control and possibility of rollover:
 - Do NOT operate near drop-offs or near water.
 - Do NOT operate on slopes greater than 15°.
 - Reduce speed and use extreme caution on slopes.
 - Avoid sudden turns or rapid speed changes.
- There is no rollover protection when the roll bar is down.
- Always keep roll bar in the raised and locked position and use seat belt.
- Read and follow rollover protection instructions and warning.

107-2112

107-2112

25A MAIN 10A PTO 25A CHARGE 15A OPT ACC

109-7330

109-7330

ENGAGE (P)

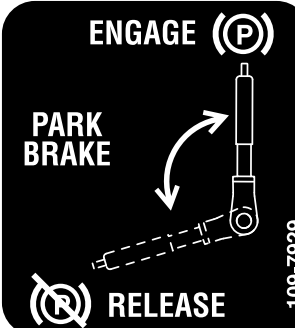

PARK BRAKE

RELEASE

109-7929

109-7929

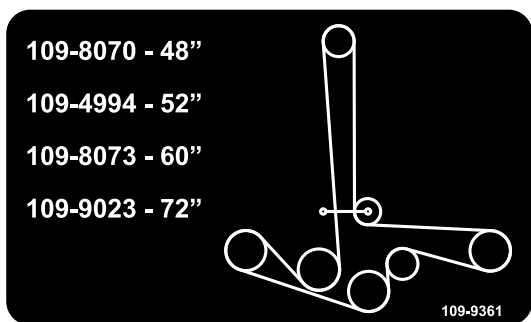

109-9361

Deck Drive Belt Routing



116-0157

1. See Operator's manual

⚠ DANGER

LPG FUEL IS EXTREMELY FLAMMABLE AND VAPORS ARE EXPLOSIVE.

To avoid serious injury or death:

- Do NOT smoke or replace tank(s) around sources of fuel ignition.
- Close fuel valve when mower is not in use, in storage, or transporting.
- ONLY use Exmark approved LPG tank(s), fittings, and hoses that were designed for your mower.
- Avoid contact with LPG fuel. Escaping vapors and liquids freezes skin on contact.
- Do NOT attempt to repair or modify the tank or its components. Contact trained and qualified personnel.
- NOTE: This is provided ONLY as a guide, consult the Operator's Manual and NFPA 58: Liquefied Petroleum Gas Code for additional safety information.

109-9875

109-9875

⚠ WARNING

ROTATING BELT DRIVE
Can cause serious injury

Stop engine and wait until all moving parts have stopped before reaching underneath.

116-0205

116-0205

SERVICE AID

116-0211

Every 50 hours:

1. Check hydraulic oil (Only use recommended hydro oil)
2. Check tire pressure in pneumatic tires - 13 psi

Yearly:

3. Grease belt idlers
4. Grease front caster pivots

See operator's manual for additional details.

116-0211

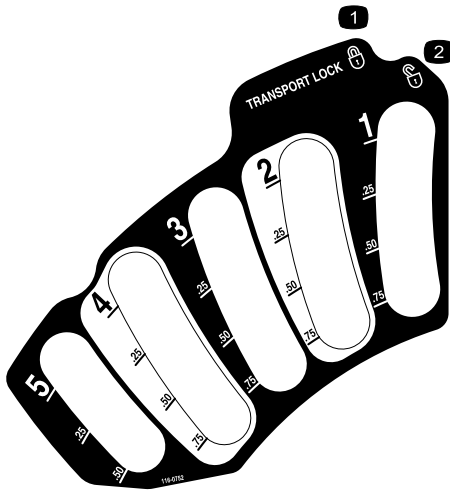

116-0752

1. Latch
2. Unlatch

CALIFORNIA SPARK ARRESTER WARNING

Operation of this equipment may create sparks that can start fires around dry vegetation. A spark arrester may be required. The operator should contact local fire agencies for laws or regulations relating to fire prevention requirements. 117-2718

117-2718

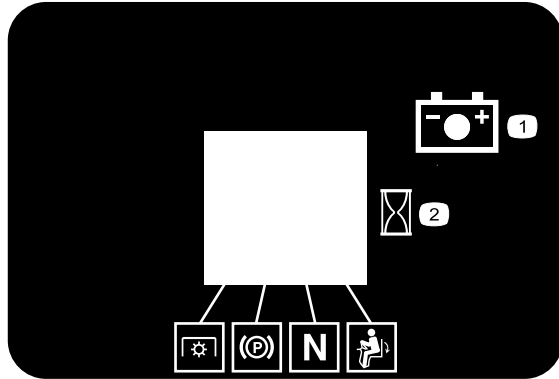

Hour Message Display

1. Hour Meter
2. PTO
3. Parking Brake
4. Neutral
5. Operator's presence switch
6. Battery

LPG TANK SPECIFICATION		116-1714	
USE EXMARK APPROVED TANK ONLY			
MOUNTING:	HORIZONTAL	CAPACITY:	43.5 LB
DISCONNECT COUPLING:	LH-ACME THREADED	FUEL WITHDRAWAL:	VAPOR

116-1714

Torque Wheel Lug Nuts to 90-95 ft-lbs (122-129 N-m).	Check after first 100 hrs then every 500 hrs thereafter. 116-2643
Torque Wheel Hub Slotted Nut to 211-260 ft-lbs (286-352 N-m). See Operator's Manual for more details.	

116-2643



116-3261

1. Throttle - fast
2. Throttle - slow

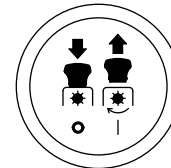

PTO Switch Symbols

1. PTO-disengage
2. PTO-engage

<p>⚠ WARNING</p> <p>To avoid serious injury or death:</p> <ul style="list-style-type: none"> • Read and understand the operator's manual before using this machine. • Do NOT operate unless trained to safely use this machine. • Do NOT operate under the influence of alcohol or drugs. • Hearing protection is recommended. • Do NOT operate without shields, guards, and safety devices in place and working. • Check the function of the operator presence controls (OPC) safety system daily. Do NOT defeat the OPC system. • Stop engine and remove key before adjusting, servicing or cleaning machine and attachments. 	<p>⚠ DANGER</p> <p>To avoid serious injury or death:</p> <ul style="list-style-type: none"> • Avoid blades unless engine and blades are stopped.  <p style="text-align: right; font-size: small;">109-7069</p>	<p>⚠ WARNING</p> <p>To avoid serious injury or death:</p> <ul style="list-style-type: none"> • Pick up objects that could be thrown by the blades. • Do NOT mow when people and pets are in the area. • Do NOT carry passengers. Look behind and to the side before changing directions. • Before leaving the operator's position: <ul style="list-style-type: none"> - Disengage PTO. - Move drive levers out to neutral lock position. - Engage park brake. - Stop engine. 
---	---	---

109-7069

<p>IMPORTANT: LPG Fuel Tank Replacement Procedure</p>	<p>109-9906</p>
<ol style="list-style-type: none"> 1. Stop the machine on a level surface, disengage PTO, and engage parking brake. 2. Close the fuel valve(s) on ALL tanks. 3. Run the engine until it stops and remove key. 4. Disconnect LPG fuel hose(s), unlatch cylinder bracket(s), and remove tank(s). 5. Check valve and fittings for debris or damaged o-rings. 6. Only use replacement tank(s) that are free of dents or damage and match size and type required on tank specification decal. 7. Install new tank(s) per mounting instructions: <ul style="list-style-type: none"> Horizontal mounting: Align center hole on tank collar over mounting pin or tab. Vertical mounting: Align notch in tank base over mounting pin or tab. 8. Latch bracket(s) and ensure tank(s) is securely fastened to mower. 9. Re-connect fuel hose(s). 10. Slowly open fuel valve(s) to equalize pressure. 11. Check for leaks. 	

109-9906

Specifications

Model Numbers

Serial Nos: 850,000 and Higher

LZAS29KA604LP; LZAS29KA724LP; LZZ29KA606LP

Systems

Engine

- Engine Specifications: See your Engine Owner's Manual
- RPM: Full Speed: 3750 ±50 RPM (PTO not engaged) Idle: 1500 ±100 RPM

Tank Type and Refilling

Important: The LPG tank used on this mower is a special tank with internal baffles designed for this application.

- Horizontal Tank Specifications:
 - Tank Material: Aluminum
 - Capacity: 43.5 lb
 - Disconnect Coupling: LH ACME Threaded
 - Fuel Withdrawal: Vapor
 - Fuel Shut-Off Valve: Rotate clockwise to close.
- Type of Fuel: HD5 grade propane
- New tanks must be properly filled by trained and qualified personnel.
- Only use tanks recommended by Exmark. Failure to do so will result in improper operation of the fuel system.

⚠ CAUTION

Under no circumstances should propane tanks filled beyond 80% capacity be used in service.

The use of overfilled tanks may result in the release of highly concentrated and extremely flammable liquid propane. Refer to the Safety section.

Note: Use of a “forklift” type liquid withdrawal tank will result in icing or freezing of the LPG regulator

and prevent the engine from operating. This may also result in permanent fuel system damage and the release of highly flammable propane liquid or vapor.

Electrical System

- Charging System: Flywheel Alternator
- Charging Capacity: 15 amps
- Battery Type: BCI Group U1
- Recommended Minimum Battery CCA: 260 CCA
- Battery Voltage: 12 Volt
- Low Voltage Light — RH control panel
- Polarity: Negative Ground
- Fuses:

All units:

- 25 amp main fuse
- 25 amp charging system fuse
- 10 amp PTO fuse
- 15 amp accessory fuse

Safety Interlock System

- LCD indicators appear for the PTO, park brake, drive levers, and operator presence in the message display on the RH control panel.
- PTO must be disengaged, brake engaged, and motion control levers out (neutral lock) to start engine. (It is not necessary for the operator to be in the seat to start the engine.)
- Operator must be in seat when PTO is engaged, brake is disengaged, or motion control levers are moved in or engine will stop.
- Engine will stop if either the left, the right, or both levers are moved from neutral lock position while brake is engaged.

Operator Controls

- Steering and Motion Control:

Note: Motion control levers are adjustable to two heights.

- Separate levers, on each side of the console, control speed and direction of travel of the respective drive wheels.
- Steering is controlled by varying the position of the levers relative to each other.
- Moving motion control levers outward (in slots) locks the drive system in neutral.
- PTO Engagement Switch: Engages electric clutch (to drive belt) which engages mower blades.
- Parking Brake Lever: Engages parking brake.
- Parking Brake Release Button: Releases parking brake.
- Deck Height Adjustment Lever: Sets cutting height to desired position.
- Deck Lift Pedal: Foot pedal that lifts deck.
- Transport Lock:
 - Latching position: Automatically latches at the transport position.
 - Unlatching position: Deck does not latch at the transport position.

Seat

- Type:
 - LZZ-LP Units: Standard seat with high back, extra wide foam padded seat cushion with internal suspension, thick bolstering, two-tone cover, armrests, integral safety switch, and seat vibration isolation system.
 - LZAS-LP Units: Standard seat with high back, extra wide foam padded seat cushion with internal suspension, thick bolstering, armrests, integral safety switch.

Optional seat accessories for units with standard seats:

- Custom ride suspension system to enhance Standard Seat. Adds approximately 3 inches (7.6 cm) to seat height.
- Deluxe suspension seat with high back, low profile foam-in-place cushion (dampened, adjustable spring suspension), armrests, and integral safety switch. Seat height remains the same.
- Seat Isolation System for reduced vibration, to enhance ride of standard seat, standard seat

with Custom Ride Seat Suspension or Deluxe Suspension Seat. Adds approximately 1 inch (2.5 cm) to seat height. Seat Isolation System is standard on all LZZ-LP units.

- Mounting:
 - LZZ-LP Units: Hinged seat frame to tilt up seat. Held in tilted position with prop rod. Adjustable fore and aft on seat tracks.
 - LZAS-LP Units: Adjustable fore and aft on seat tracks.
 - Armrests:
 - ◇ Standard seat: foam padded adjustable flip-up armrests.
 - ◇ Suspension seat: molded adjustable flip-up armrests.
 - Seat Safety Switch:

Integrated seat switch. Time delay seat switch eliminates rough ground cut-outs.

Hydrostatic Ground Drive System

- Two unitized hydrostatic transmissions:
 - LZZ-LP Units:
 - ◇ 16cc Parker axial piston pump
 - ◇ 280cc Ross geroler motor
 - LZAS-LP Units:
 - ◇ 12cc Parker axial piston pump
 - ◇ 240cc Parker geroler motor
- Hydraulic Oil Type: Exmark Premium Hydro oil.
- Hydraulic Oil Capacity: 52 oz (1.5 L) per side
- Hydraulic Filter: P/N 116-0164
- Speeds:
 - 12cc
 - ◇ 0-10 mph (16.1 km/hr) forward.
 - ◇ 0-5.5 mph (8.9 km/hr) reverse.
 - 16cc
 - ◇ 0-11.5 mph (18.5 km/hr) forward.
 - ◇ 0-6 mph (9.7 km/hr) reverse.
- Drive wheel release valves allow machine to be moved when engine is not running.

Specifications

Tires & Wheels

	Drive
	Pneumatic (Air filled)
Quantity	2
Tread	“Multi-Trac C/S”
Size	24 x 12.00-12
Ply Rating	4
Pressure	13 psi (90 kPa)

	Front Caster		
	Semi-Pneumatic		
Model	LZAS-LP	LZAS-LP	LZZ-LP
Deck Size	60	72	60
Quantity	2	2	2
Tread	Smooth	Smooth	Smooth
Size	13 x 5.00-6	13 x 6.50-6	13 x 6.50-6
Ply Rating	—	—	—
Pressure	—	—	—

Cutting Deck

- Cutting Width:
 - 60 inch Deck: (152.4 cm)
 - 72 inch Deck: (182.9 cm)
- Discharge: Side
- Blade Size: (3 ea.)
 - 60 inch Deck: 20.50 inches (52.1 cm)
 - 72 inch Deck: 24.50 inches (62.2 cm)
- Blade Spindles:
 - LZZ-LP Units: Solid steel spindles with 1.18 inch (30 mm) I.D. bearings.
 - LZAS-LP Units: Solid steel spindles with 1.00 inch (25 mm) I.D. bearings.
- Deck Drive:

Electric clutch. Shaft diameter 1.125 inches (2.86 cm)

60 and 72 inch Decks: 5V Section belt with self-tensioning idler.
- Deck:

Full floating deck is attached to out-front support frame. Anti-scalp rollers provide maximum turf

protection. Deck design allows for bagging, mulching or side discharge.

- 60 inch Deck: 4 anti-scalp rollers
- 72 inch Deck: 4 anti-scalp rollers
- Deck Depth:
 - 60 inch Deck: 5.5 inches (14 cm)
 - 72 inch Deck: 5.5 inches (14 cm)
- Cutting Height Adjustment:

Foot activated lever is used to adjust the cutting height from 1 inch (2.5 cm) to 5 1/2 inches (14 cm) in 1/4 inch (6.4 mm) increments.
- Mulching Kit: Optional.

Dimensions

Overall Width:

	60 inch Deck	72 inch Deck
Without Deck	53.0 inches (134.6 cm)	59.1 inches (150.1 cm)
Deflector Up	62.5 inches (158.8 cm)	73.5 inches (186.7 cm)
Deflector Down	72.8 inches (184.9 cm)	84.9 inches (215.6 cm)

Overall Length:

	60 inch Deck	72 inch Deck
Roll Bar - Up	83.1 inches (211.1 cm)	86.1 inches (218.7 cm)
Roll Bar - Down	84.8 inches (215.4 cm)	87.8 inches (223.0 cm)

Overall Height:

Roll Bar - Up	Roll Bar - Down
70.5 inches (179.1 cm)	46.8 inches (118.9 cm)

Tread Width: (Center to Center of Tires, Widthwise)

	60 inch Deck	72 inch Deck
Drive Wheels	41.6 inches (105.7 cm)	43.6 inches (110.7 cm)
Caster Wheels	39.5 inches (100.3 cm)	47.1 inches (119.6 cm)

Wheel Base: (Center of Caster Tire to Center of Drive Tire)

LZZ-LP Units:

60 inch Deck
50.6 inches (128.5 cm)

LZAS-LP Units:

60 inch Deck	72 inch Deck
51.6 inches (131.1 cm)	53.6 inches (136.1 cm)

Curb Weight:

LZZ-LP Units:

	60 inch Deck
29HP Kawasaki Units	1342 lb (609 kg)

LZAS-LP Units:

	60 inch Deck	72 inch Deck
29HP Kawasaki Units	1283 lb (582 kg)	1338 lb (607 kg)

Accessory Weight Table Worksheet:

Use the table below to determine if extra weight is required for the unit. Identify the accessories and correct deck size and place the corresponding values in the Accessory Score column. If the Total Accessory Score meets the following, add the recommended weight kit.

Note: The 72 inch deck does not require a weight kit.

	60 inch Deck	Accessory Score
Light Kit	2	
Michigan Seat/CRSS	3	
Bagger	3	
Pneumatic Caster Tires	5	
Mulch Kit	-5	
Striper Kit	0	
OCD02	-4	
Hitch Kit	1	
Sunshade Kit	2	
Total Accessory Score		

Total Accessory Score	Required Weight Kit(s)
0 – 9	None required
10 – 19	*116-1173 Under toe board mount weight kit
20 and Higher	*Two 116-1173 Under toe board mount weight kits or one 116-1173 Under toe board mount weight kit and one 116-1238 Front toe board mount weight kit

*60 inch units which already have an under toe board mount weight as standard requires 116-1238 front toe board top mount kit instead of 116-1173.

Product Overview

Torque Requirements

Bolt Location	Torque
Blade Drive Sheave Mounting Nut	
LZZ-LP Units:	90-110 ft-lb (122-149 N-m)
LZAS-LP Units:	140-145 ft-lb (190-197 N-m)
Cutter Housing Spindle Nut (LZZ-LP Units Only)	160-185 ft-lb (217-251 N-m)
Blade Mounting Bolt (lubricate with anti-seize)	55-60 ft-lb (75-81 N-m)
Anti-Scalp Roller Hex Capscrew	
LZZ-LP Units: See Figure 18	50-55 ft-lb (68-75 N-m)
Anti-Scalp Roller Nyloc Nut	
LZZ-LP Units: See Figure 18	30-35 ft-lb (41-47 N-m)
LZAS-LP Units: See Figure 19	30-35 ft-lb (41-47 N-m)
Anti-Scalp Roller Whizlock Nut	
LZAS-LP Units: See Figure 19	30-35 ft-lb (41-47 N-m)
Engine Mounting Bolts	27-33 ft-lb (37-45 N-m)
Wheel Lug Nuts	90-95 ft-lb (122-129 N-m)
Wheel Motor Mounting Bolts	72-77 ft-lb (98-104 N-m)
Wheel Hub Slotted Nut	211-260 ft-lb (286-352 N-m)
Rollover Protection System (Roll Bar) 1/2 inch Mounting Bolts	75-80 ft-lb (102-108 N-m)
Clutch Retaining Bolt (secured with threadlocker)	55-60 ft-lb (75-81 N-m)
Hydro Park Brake Cable Anchor 1/2 inch Mounting Bolt (secured with threadlocker)	67-89 ft-lb (91-121 N-m)

Product Overview

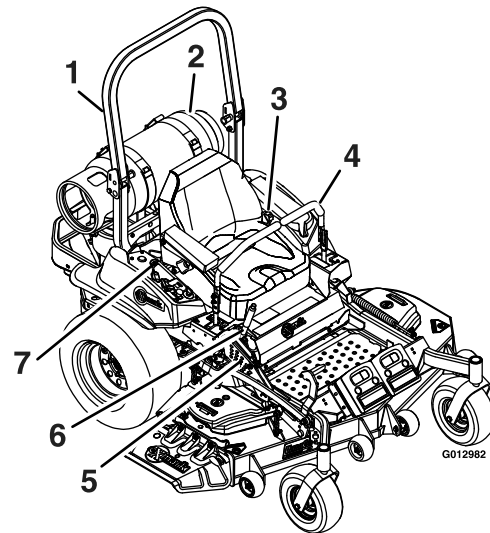

Figure 4

- | | |
|--------------------------------------|-----------------------------|
| 1. Rollover Protection System (ROPS) | 5. Height of cut adjustment |
| 2. LPG tank | 6. Parking brake |
| 3. Seat belt | 7. Engine controls |
| 4. Motion control levers | |

Operation

Note: Determine the left and right sides of the machine from the normal operating position.

Controls

Motion Control Levers

The motion control levers located on each side of the console control the forward and reverse motion of the machine.

Moving the levers forward or backward turns the wheel on the same side forward or reverse respectively. Wheel speed is proportional to the amount the lever is moved.

Moving the levers outward from the center position into the T-slot locks them in the neutral position (Figure 5).

When the motion control levers are in the neutral position, the LCD indicator appears in the message display on the RH console (see Figure 9).

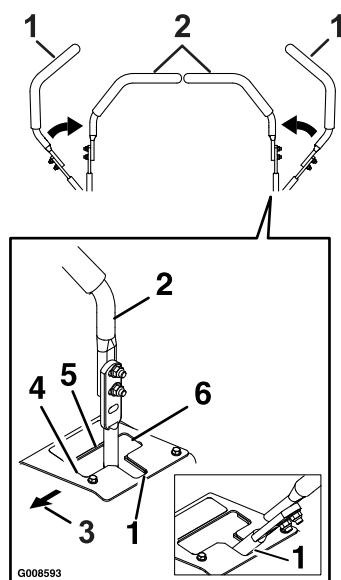

Figure 5

- | | |
|--|----------------------|
| 1. Neutral lock position (handles out) | 4. Forward |
| 2. Neutral operate position (handles in) | 5. Neutral (operate) |
| 3. Front of Unit | 6. Reverse |

Throttle Control

Located on right console (red lever) (see Figure 6).

The throttle is used to control engine speed. Moving the throttle lever forward will increase engine speed and moving the throttle lever to the rear will decrease engine speed. Moving the throttle forward into the detent is full throttle.

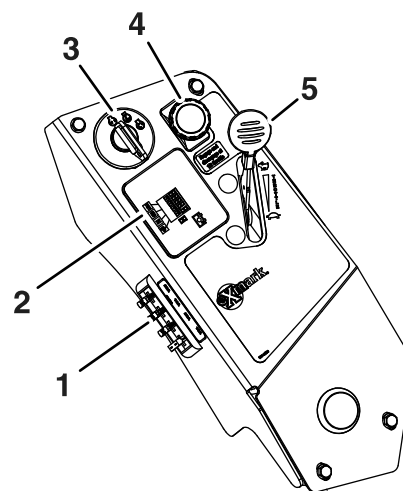

G012984

Figure 6
Right Console

- | | |
|--------------------|--------------------------|
| 1. Fuses | 4. PTO engagement switch |
| 2. Message display | 5. Throttle |
| 3. Ignition switch | |

Brake Lever

Located on right side of unit, just to the front of the RH motion control lever.

The brake lever engages a parking brake on the drive wheels.

Note: The LCD indicator appears in the message display on the RH console when the park brake is engaged (see Figure 9).

Pull the lever up and rearward to engage the brake.

Depress the release button and push downward to disengage the brake.

Operation

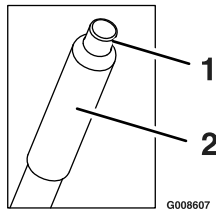

Figure 7

1. Release button
2. Park brake

The unit must be tied down and brake engaged when transporting.

Ignition Switch

Located on right console (see Figure 6).

The ignition switch is used to start and stop the engine. The switch has three positions “OFF”, “ON” and “START”. Insert key into switch and rotate clockwise to the “ON” position. Rotate clockwise to the next position to engage the starter (key must be held against spring pressure in this position). Allow the key to return to the “on” position immediately after the engine starts.

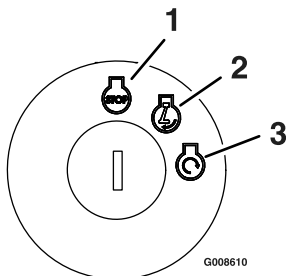

Figure 8

1. Off
2. On
3. Start

Note: Brake must be engaged, motion control levers out (neutral lock position) and PTO switch disengaged to start engine. (It is not necessary for the operator to be in the seat to start the engine.)

Hour Meter

Located on the right console in the message display (see Figure 6 and Figure 9).

The hour meter records the number of hours that the engine has run.

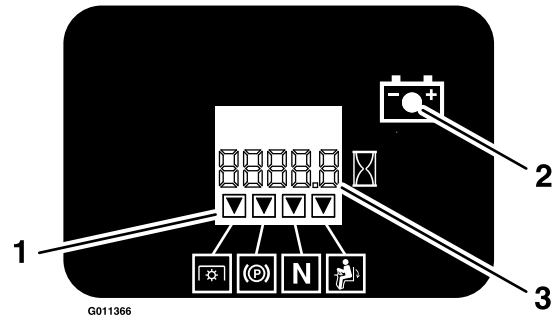

Figure 9

1. LCD Indicators
2. Low voltage indicator light
3. Hour/Voltage display

The hour meter is recording when the decimal point is flashing in Hour/Voltage display.

Hours are displayed when the key is off or when the machine is running.

Note: If the ignition key is turned to the “ON” position for a few seconds before cranking the engine, the battery voltage will display in the area where the hours are normally displayed.

Note: The LCD indicators appear when each control meets the “safe to start” mode (e.g. the indicator turns on when the operator is in the seat.)

Fuel Valve

Located on the LPG fuel tank.

The fuel valve is used to open and close the fuel supply when the machine is not in use, during transport to and from the jobsite, and when parked inside a well-ventilated building.

Rotate the fuel valve clockwise to turn off the fuel. Rotate fuel valve counterclockwise to turn on the fuel.

Fuel Gauge

Located on the LPG fuel tank.

This gauge monitors the amount of liquid LPG in the fuel tank.

Safety Pressure Relief Valve

Located on the LPG fuel tank.

The safety pressure relief valve relieves the excess pressure in the LPG tank.

Important: This valve has a protective plastic cap that should **NEVER** be removed. If the cap is damaged or missing, contact trained and qualified personnel immediately.

LPG Cylinder Brackets

The brackets are located on the engine deck.

The LPG cylinder brackets are used to fasten the removable LPG tank to the mower.

Drive Wheel Release Valves

⚠ WARNING

Hands may become entangled in the rotating drive components below the engine deck, which could result in serious injury or death.

Stop engine, remove key, allow all the moving parts to stop before accessing the drive wheel release valves.

⚠ WARNING

The engine and hydraulic drive units can become very hot. Touching a hot engine or hydraulic drive units can cause severe burns.

Allow the engine and hydraulic drive units to cool completely before accessing the drive wheel release valves.

Located on the back of the unitized hydraulic drive units, below the engine deck.

During normal operating conditions, the drive wheel release valves are positioned horizontally. If the machine has to be pushed by hand, the valves must be in the “released” position (see Figure 10).

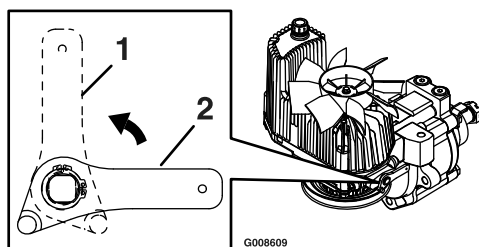

Figure 10

1. Handle in “released” position
2. Handle in “operating” position

To release the drive system (see item 1 in Figure 10), rotate the handle 1/4 turn to the vertical position until it hits against the stop.

To reset the drive system (see item 2 in Figure 10), rotate the handle 1/4 turn to the horizontal position until it hits against the stop.

Note: The handle must be horizontal and against the stop for operation.

Do Not tow machine.

PTO Engagement Switch

Located on right console (see Figure 6).

Switch must be pulled out (up) to engage the blades. Switch is pushed in to disengage the blades.

The LCD indicator will appear when the PTO switch is disengaged (see Figure 9).

Low Voltage Indicator

Located on the right console in the message display (see Figure 6 and Figure 9).

A low voltage condition (less than 12.3 volts) exists when the LCD indicator appears on the message display while the engine is running.

If the ignition key is turned to the “ON” position for a few seconds before cranking the engine, the battery voltage will display in the area where the hours are normally displayed.

Note: The indicator normally appears when the engine is off and the key switch is turned to the “ON” position.

Deck Lift Pedal

Located at the right front corner of the floor pan.

Push the pedal forward with your foot to raise the cutting deck. Allow the pedal to move rearward to lower the cutting deck to the cut height that has been set.

Transport Lock

Located on the height of cut adjustment plates to the right of the parking brake.

Position in the transport latching position to automatically latch the cutting deck when raised to the transport position (see item 1 in Figure 11).

Operation

In the non-latching position, the deck will automatically return to the cutting height when the pedal is lowered (see item 3 in Figure 11).

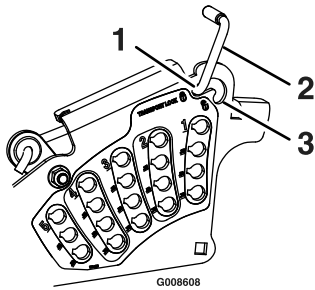

Figure 11

1. Latching position
2. Transport lock control
3. Non-latching position

Pre-Start

LPG tanks supplied from Exmark Do Not contain LPG fuel for shipping reasons and safety. Have the LPG tanks filled by trained and qualified personnel. For best results, use clean, fresh HD5 grade propane.

Do Not allow the LPG tanks to be overfilled. Overfilling LPG tanks builds excess pressure within the tank which causes the relief valve to open.

Make sure you understand the controls, their locations, their functions, and their safety requirements.

Refer to the Maintenance section and perform all the necessary inspection and maintenance steps.

Operating Instructions

Raise the Rollover Protection System (ROPS)

Important: The roll bar is an integral and effective safety device. Keep the roll bar in the raised and locked position when operating the mower. Lower the roll bar temporarily only when absolutely necessary.

1. The knob must be completely latched with the tabs interlocking as shown in Figure 12 to lock the roll bar in the raised, operate position.
2. Apply forward pressure to the upper hoop of the roll bar.
3. Pull the knob and rotate 90° to hold in the unlatched position to lower the roll bar.

4. To return to the operate position, raise the roll bar, and then rotate knobs 90° so that the tabs interlock partially. Apply forward pressure to the roll bar upper hoop and observe that the knobs return to the completely latched position.

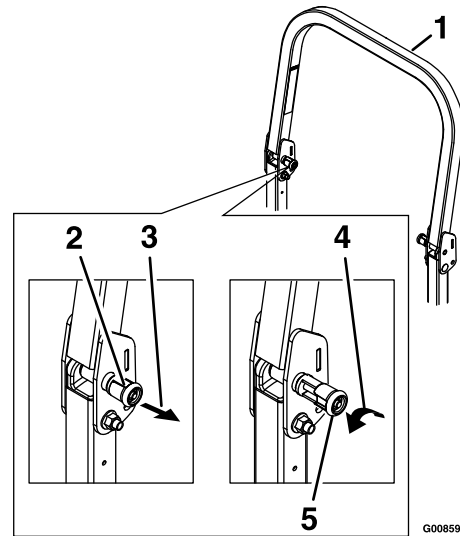

Figure 12

1. Roll bar upper hoop
2. Knob in "latched" position
3. Pull knob to unlatch
4. Rotate 90° to hold unlatched
5. Knob in "unlatched" position

5. Make sure the knobs are fully engaged with the roll bar in the raised position. The upper hoop of the roll bar may need to be pushed forward or pulled rearward to get both knobs fully engaged (see Figure 13).

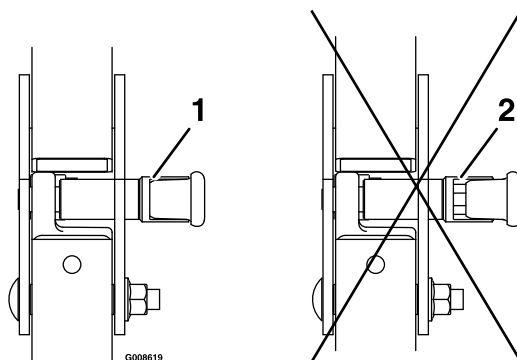

Figure 13

1. Engaged
2. Partially engaged — Do Not operate with ROPS in this condition.

Important: Always use the seat belt with the roll bar in the operate (raised) position. Ensure

that the rear part of the seat is secured with the seat latch.

Open the Fuel Valve

1. Slowly open the fuel valve to equalize the pressure in the tank. The fuel valve is located on the top end of the LPG tank. If the fuel valve is opened too quickly, the pressure relief valve is equipped with a back pressure check valve that will shut off the fuel supply. If this happens, close the fuel valve completely and wait five seconds. Slowly open the fuel valve.
2. Rotate the fuel valve counterclockwise to turn on the fuel. If leaks are detected, refer to the leak information in the **Inspection** section in Safety.

Starting the Engine

1. Move the motion control levers out to the neutral lock position.
2. Pull up and back on the parking brake lever to engage the parking brake.
3. Push in on the PTO switch to the “STOP” position.

Note: It is not necessary for the operator to be in the seat to start the engine.

4. Place the throttle in the “SLOW” position.
5. Turn ignition switch to the “START” position. Release the switch as soon as the engine starts.

Important: Do Not crank the engine continuously for more than ten seconds at a time. If the engine does not start, allow a 60 second cool-down period between starting attempts. Failure to follow these guidelines can burn out the starter motor.

Engaging the PTO

⚠ DANGER

The rotating blades under the mower deck are dangerous. Blade contact can cause serious injury or kill you.

Do Not put hands or feet under the mower or mower deck when the blades are engaged.

⚠ DANGER

An uncovered discharge opening will allow objects to be thrown in an operator’s or bystander’s direction. Also, contact with the blade could occur. Thrown objects or blade contact can cause serious injury or death.

Never operate the mower with the discharge deflector raised, removed, or altered unless there is a grass collection system or mulch kit in place and working properly.

The PTO push-pull switch engages the cutting blades. Be sure that all persons are clear of the mower deck and discharge area before engaging PTO.

Important: Operator must be in seat before the PTO can be engaged.

1. Set the throttle midway between the “SLOW” and “FAST” positions.
2. Pull the PTO switch outward to engage the blades.
3. Place the throttle in the “FAST” position to begin mowing.

Disengaging the PTO

1. Set the throttle midway between the “SLOW” and “FAST” positions.
2. Push the PTO switch in to disengage the blades.

Stopping the Engine

1. Bring the unit to a full stop.
2. Disengage the PTO.
3. Move the motion control levers out to the neutral lock position.
4. Engage the parking brake.
5. Place the throttle in the “SLOW” position.
6. Turn off the fuel valve and allow the engine to run out of fuel. Failure to do this may cause the engine to “flood” when re-starting.
7. Turn the ignition switch to the “OFF” position once the engine has stopped.
8. Remove the key to prevent children or other unauthorized persons from starting engine.

Operation

Driving the Machine

⚠ CAUTION

Machine can spin very rapidly by positioning one lever too much ahead of the other. Operator may lose control of the machine, which may cause damage to the machine or injury.

- Use caution when making turns.
- Slow the machine down before making sharp turns.

Important: To begin movement (forward or backward) the operator must be in the seat, the brake lever must be disengaged (pushed down) before the motion control levers can be moved in or the engine will stop.

When the motion control levers are positioned fully outward (apart) in the T-slot, the drive system is in the neutral lock position (Figure 14).

Note: The “N” LCD indicator appears when both levers are in the neutral lock position.

When the motion control levers are moved directly inward (together) the drive system is in the neutral operate position.

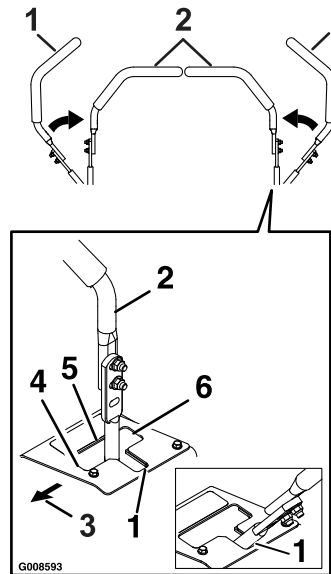

Figure 14

- | | |
|--|----------------------|
| 1. Neutral lock position (handles out) | 4. Forward |
| 2. Neutral operate position (handles in) | 5. Neutral (operate) |
| 3. Front of Unit | 6. Reverse |

Driving Forward

1. Release the parking brake.
2. Move the motion control levers inward to the center to the neutral position.
3. To move forward in a straight line, move both levers forward with equal pressure.

To turn left or right, pull the motion control lever back toward neutral in the desired turn direction.

The machine will move faster the farther the motion control levers are moved from the neutral position.

4. To stop, position both motion control levers in the neutral operate position.

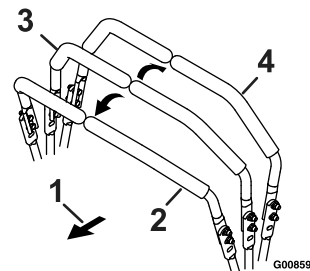

Figure 15

- | | |
|------------------|------------|
| 1. Front of Unit | 3. Neutral |
| 2. Forward | 4. Reverse |

Driving in Reverse

1. Move the motion control levers inward to the neutral operate position.
2. To move rearward in a straight line, move both levers rearward with equal pressure.

To turn right, release pressure on the RH motion control lever and the rear of the machine will move towards the rear and to the right.

To turn left, release pressure on the LH motion control lever and the rear of the machine will move towards the rear and to the left.

3. To stop, position both motion control levers in the neutral operate position.

Adjusting the Cutting Height

The cutting height of the mower deck is adjusted from 1 to 5 1/2 inches (2.5 cm to 14 cm) in 1/4 inch (6.4 mm) increments.

1. Stop the machine and move the motion control levers outward to the neutral locked position.
2. Disengage the PTO.
3. Position the transport lock in the latching position.
4. Raise and lock the deck to the 5 1/2 inch (14 cm) transport position (Figure 16).

The deck is raised by pushing the foot operated deck lift pedal forward. The pedal is located at the front right corner of the floor pan.

Note: When changing the cutting height positions, always come to a complete stop and disengage the PTO.

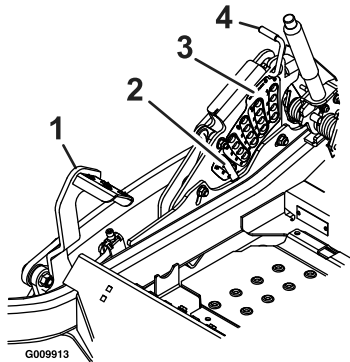

Figure 16
LZAS-LP Unit Shown

- | | |
|--------------------------|---------------------------|
| 1. Deck foot pedal | 3. Height of cut decal |
| 2. Height adjustment pin | 4. Transport lock control |

5. Insert the height adjustment pin into the hole corresponding to the desired cutting height.
See the decal on the side of the deck lift plate for cut heights.
6. Push the deck lift pedal, release the transport lock and allow the deck to lower to the cutting height.

Adjusting the Anti-Scalp Rollers

It is recommended to change the anti-scalp roller position, when the height of cut has changed.

1. Stop the machine and move the motion control levers outward to the neutral locked position.
2. Disengage the PTO.
3. Engage the park brake.
4. Stop the engine, remove the key and wait for all moving parts to stop.
5. After adjusting the height of cut:
 - LZZ-LP Units: Adjust the anti-scalp rollers by removing the bushing, spring disc washer and bolt.
 - LZAS-LP Units: Adjust the anti-scalp rollers by removing the nyloc nut, bushing, spring disc washer and whizlock nut.
6. Place the rollers in one of the positions shown (Figure 17). Rollers will maintain 3/4 inch (19 mm) clearance to the ground to minimize gouging and roller wear or damage.

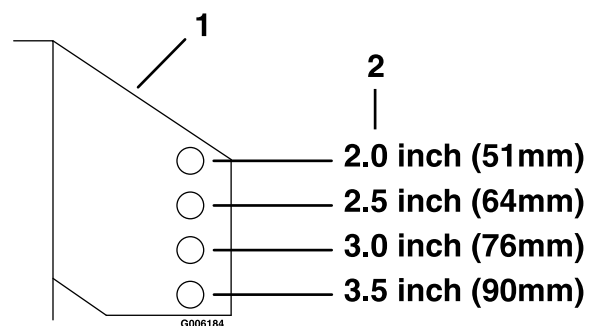

Figure 17

For cutting heights above 3.5 inches (90 mm) use the bottom hole. The rollers will still be effective against scalping.

- | | |
|---------------------------------------|-------------------|
| 1. Anti-scalp roller mounting bracket | 2. Cutting height |
|---------------------------------------|-------------------|

For Maximum Deck Flotation, place the rollers one hole position lower. Rollers should maintain

Operation

1/4 inch (6.4 mm) clearance to the ground. **Do Not** adjust the rollers to support the deck.

7. For LZZ-LP Units: Be sure the roller bolts are installed with the spring disc washer between the head of the bolt and the mounting bracket (Figure 18).

For LZAS-LP Units: Be sure the whizlock nuts are installed with the spring disc washer between the head of the nut and the mounting bracket (Figure 19).

Note: The foot operated deck lift assist lever can be used to momentarily lift the deck to clear objects. Be sure that PTO is disengaged.

- For LZZ-LP Units:

Torque the 3/8–24 x 2 Gr 8 hex capscrew to 50–55 ft-lb (68–75 N-m) (Figure 18).

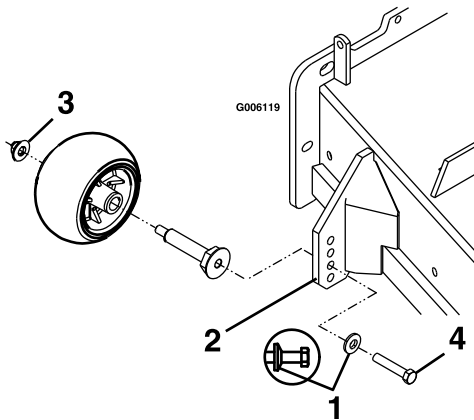

Figure 18

- | | |
|--|---|
| 1. Spring disc washer (cone towards bolt head) | 3. 3/8 nyloc-torque to 30-35 ft-lb (41-47 N-m) |
| 2. Front right anti-scalp bracket shown | 4. 3/8-24 x 2 GR8 torque to 50-55 ft-lb (68-75 N-m) |

- For LZAS-LP Units:

- A. Torque the 3/8–16 whizlock nut to 30-35 ft-lb (41-47 N-m) (Figure 19).
- B. Torque the 3/8 nyloc nut to 30–35 ft-lb (41-47 N-m).

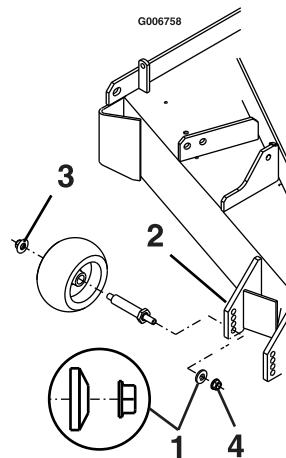

Figure 19

- | | |
|--|--|
| 1. Spring disc washer (cone towards nut) | 3. 3/8 nyloc-torque to 30-35 ft-lb (41-47 N-m) |
| 2. Front right anti-scalp bracket shown | 4. 3/8-16 whizlock nut torque to 30-35 ft-lb (41-47 N-m) |

Transporting

Transporting a Unit

Use a heavy-duty trailer or truck to transport the machine. Lock brake and block wheels. Securely fasten the machine to the trailer or truck with straps, chains, cable, or ropes. Be sure that the trailer or truck has all necessary lighting and marking as required by law. Secure a trailer with a safety chain.

CAUTION

This unit does not have proper turn signals, lights, reflective markings, or a slow moving vehicle emblem. Driving on a street or roadway without such equipment is dangerous and can lead to accidents causing personal injury. Driving on a street or roadway without such equipment may also be a violation of State laws and the operator may be subject to traffic tickets and/or fines.

Do Not drive a unit on a public street or roadway.

WARNING

Loading a unit on a trailer or truck increases the possibility of backward tip-over. Backward tip-over could cause serious injury or death.

- Use extreme caution when operating a unit on a ramp.
- Use only a single, full width ramp; Do Not use individual ramps for each side of the unit.
- If individual ramps must be used, use enough ramps to create an unbroken ramp surface wider than the unit.
- Do Not exceed a 15° angle between ramp and ground or between ramp and trailer or truck.
- Avoid sudden acceleration while driving unit up a ramp to avoid tipping backward.
- Avoid sudden deceleration while backing unit down a ramp to avoid tipping backward.

WARNING

Loading the mower onto a trailer without strong enough or properly supported ramps could be dangerous. The ramps could collapse causing the unit to fall, which could cause injury.

- Use proper ramps that are secured to the truck or trailer.
- Keep feet and legs out from under the unit when loading and unloading.
- If necessary, use assistance when loading.

Consult the NFPA 58: Liquefied Petroleum Gas Code for additional information regarding LPG transportation.

- Be sure the fuel valve is closed on the tank(s).
- Place spare LPG tank(s) in a DOT approved storage cage.
 - Transport tanks in an upright, vertical and secure position to minimize movement,

tipping, or physical damage relative to other tanks or to the storage cage while in transit.

- Place tanks so that valves, fittings, or gauges are protected from physical damage during transport.
- Place tank(s) in a well-ventilated trailer.
- Do Not store the tank(s) or machine with tank(s) in an area where the temperature can rise above 120°F (49°C). If the temperature exceeds approximately 160°F (71°C), the tank will release highly flammable propane vapor. See Preparation in the Safety Section.
- Do Not transport LPG tank(s) in the passenger space of a vehicle.
- Do Not transport leaking fuel tanks.
- Trailers must have appropriate markings to transport LPG.
- Follow NFPA 58 and state and local regulations for transporting LPG.

Loading a Unit

Use extreme caution when loading units on trailers or trucks. One full width ramp that is wide enough to extend beyond the rear tires is recommended instead of individual ramps for each side of the unit. The lower rear section of the tractor frame extends back between the rear wheels and serves as a stop for tipping backward. Having a full width ramp provides a surface for the frame members to contact if the unit starts to tip backward. If it is not possible to use one full width ramp, use enough individual ramps to simulate a full width continuous ramp.

Ramp should be long enough so that the angles between the ramp and the ground and the ramp and the trailer or truck do not exceed 15°. A steeper angle may cause mower deck components to get caught as the unit moves from ramp to trailer or truck. Steeper angles may also cause the unit to tip backward. If loading on or near a slope, position the trailer or truck so it is on the down side of the slope and the ramp extends up the slope. This will minimize the ramp angle. The trailer or truck should be as level as possible.

Important: Do Not attempt to turn the unit while on the ramp, you may lose control and drive off the side.

Operation

Avoid sudden acceleration when driving up a ramp and sudden deceleration when backing down a ramp. Both maneuvers can cause the unit to tip backward.

Maintenance

Note: Determine the left and right sides of the machine from the normal operating position.

⚠ WARNING

While maintenance or adjustments are being made, someone could start the engine. Accidental starting of the engine could seriously injure you or other bystanders.

Remove the key from the ignition switch, engage parking brake, and pull the wire(s) off the spark plug(s) before you do any maintenance. Also push the wire(s) aside so it does not accidentally contact the spark plug(s).

⚠ WARNING

The engine can become very hot. Touching a hot engine can cause severe burns.

Allow the engine to cool completely before service or making repairs around the engine area.

Recommended Maintenance Schedule(s)

Maintenance Service Interval	Maintenance Procedure
After the first 5 hours	<ul style="list-style-type: none"> • Change the engine oil.
After the first 100 hours	<ul style="list-style-type: none"> • Check the wheel hub slotted nut torque specifications. • Check the wheel lug nuts. • Check the park brake adjustment.
Before each use or daily	<ul style="list-style-type: none"> • Check the engine oil level. • Check the mower blades. • Check the safety interlock system. • Check the rollover protections systems (roll bar) knobs. • Check the seat belt. • Check for loose hardware. • Check the LPG tank and components. • Clean the engine and exhaust system area. • Clean the hydro fan cooling guards. • Clean the grass and debris build-up from the machine and cutting deck. • Clean the grass build-up from under the cutting deck.
Every 40 hours	<ul style="list-style-type: none"> • Check the entire LPG fuel delivery system.
Every 50 hours	<ul style="list-style-type: none"> • Check the hydraulic oil level. • Check the tire pressures. • Check the condition of the belts.
Every 100 hours	<ul style="list-style-type: none"> • Change the engine oil. (May need more often under severe conditions.) • Lubricate the deck lift pivots. • Remove the engine shrouds and clean the cooling fins.
Every 200 hours	<ul style="list-style-type: none"> • Lubricate the brake handle pivot. • Check the spark plugs.
Every 250 hours	<ul style="list-style-type: none"> • Replace the primary air cleaner element — check secondary air cleaner element; replace if dirty. (May need more often under severe conditions. See the Engine Owner's Manual for additional information.)

Maintenance

Maintenance Service Interval	Maintenance Procedure
Every 500 hours	<ul style="list-style-type: none"> • Replace the secondary air cleaner element (May need more often under severe conditions. See the Engine Owner's Manual for additional information.) • Change the hydraulic filter and fluid. • Check the wheel hub slotted nut torque specifications. • Check the wheel lug nuts. • Check the park brake adjustment.
Yearly	<ul style="list-style-type: none"> • Grease the deck and pump idler pivots. • Grease the front caster pivots.

Periodic Maintenance

Check Engine Oil Level

Service Interval: Before each use or daily

1. Stop engine and wait for all moving parts to stop. Make sure unit is on a level surface.
2. Check with engine cold.
3. Clean area around dipstick. Remove dipstick and wipe oil off. Reinsert the dipstick according to the engine manufacturer's recommendations. Remove the dipstick and read the oil level.
4. If the oil level is low, wipe off the area around the oil fill cap, remove cap and fill to the "FULL" mark on the dipstick. Use oil as specified in Engine Owner's Manual. **Do Not** overfill.

Important: Do Not operate the engine with the oil level below the "LOW" (or "ADD") mark on the dipstick, or over the "FULL" mark.

Check Battery Charge

Service Interval: As required

⚠ WARNING

**CALIFORNIA
Proposition 65 Warning**

Battery posts, terminals, and related accessories contain lead and lead compounds, chemicals known to the State of California to cause cancer and reproductive harm. Wash hands after handling.

performance and service life. To preserve optimum battery performance and life, recharge batteries in storage when the open circuit voltage drops to 12.4 volts.

Note: To prevent damage due to freezing, battery should be fully charged before putting away for winter storage.

Check the voltage of the battery with a digital voltmeter or with the message display. If the ignition key is turned to the "on" position for a few seconds, the battery voltage will be displayed in the area where the hours are normally displayed. Locate the voltage reading of the battery in the table and charge the battery for the recommended time interval to bring the charge up to a full charge of 12.6 volts or greater.

Important: Make sure the negative battery cable is disconnected and the battery charger used for charging the battery has an output of 16 volts and 7 amps or less to avoid damaging the battery (see chart for recommended charger settings).

Voltage Reading	Percent Charge	Maximum Charger Settings	Charging Interval
12.6 or greater	100%	16 volts/7 amps	No Charging Required
12.4 – 12.6	75–100%	16 volts/7 amps	30 Minutes
12.2 – 12.4	50–75%	16 volts/7 amps	1 Hour
12.0–12.2	25–50%	14.4 volts/4 amps	2 Hours

Allowing batteries to stand for an extended period of time without recharging them will result in reduced

Voltage Reading	Percent Charge	Maximum Charger Settings	Charging Interval
11.7–12.0	0–25%	14.4 volts/4 amps	3 Hours
11.7 or less	0%	14.4 volts/2 amps	6 Hours or More

Recommended Jump Starting Procedure

Service Interval: As required

1. Check the weak battery for terminal corrosion (white, green, or blue “snow”), it must be cleaned off prior to jump starting. Clean and tighten connections as necessary.

⚠ CAUTION

Corrosion or loose connections can cause unwanted electrical voltage spikes at anytime during the jump starting procedure.

Do Not attempt to jump start with loose or corroded battery terminals or damage to the engine may occur.

⚠ DANGER

Jump starting a weak battery that is cracked, frozen, has low electrolyte level, or an open/shorted battery cell, can cause an explosion resulting in serious personal injury.

Do Not jump start a weak battery if these conditions exist.

2. Make sure the booster is a good and fully charged lead acid battery at 12.6 volts or greater. Use properly sized jumper cables (4 to 6 AWG) with short lengths to reduce voltage drop between systems. Make sure the cables are color coded or labeled for the correct polarity.

⚠ CAUTION

Connecting the jumper cables incorrectly (wrong polarity) can immediately damage the electrical system.

Be certain of battery terminal polarity and jumper cable polarity when hooking up batteries.

Note: The following instructions are adapted from the SAE J1494 Rev. Dec. 2001 – Battery Booster Cables – Surface Vehicle Recommended Practice (SAE – Society of Automotive Engineers).

⚠ WARNING

Batteries contain acid and produce explosive gases.

- Shield the eyes and face from the batteries at all times.
- Do Not lean over the batteries.

Note: Be sure the vent caps are tight and level. Place a damp cloth, if available, over any vent caps on both batteries. Be sure the vehicles do not touch and that both electrical systems are off and at the same rated system voltage. These instructions are for negative ground systems only.

3. Connect the positive (+) cable to the positive (+) terminal of the discharged battery that is wired to the starter or solenoid as shown in Figure 20.

Maintenance

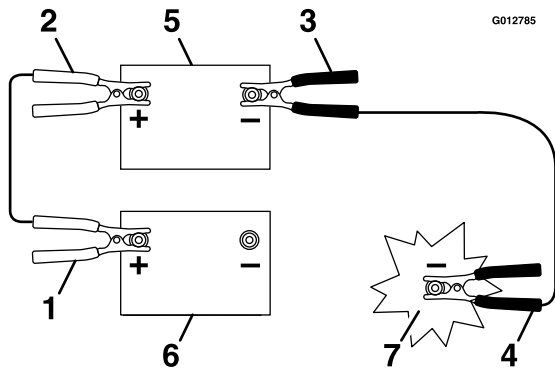

Figure 20

1. Positive (+) cable on discharged battery
2. Positive (+) cable on booster battery
3. Negative (-) cable on the booster battery
4. Negative (-) cable on the engine block
5. Booster battery
6. Discharged battery
7. Engine block

4. Connect the other end of the positive cable to the positive terminal of the booster battery.
5. Connect the black negative (-) cable to the other terminal (negative) of the booster battery.
6. **MAKE THE FINAL CONNECTION ON THE ENGINE BLOCK OF THE STALLED VEHICLE (NOT TO THE NEGATIVE POST) AWAY FROM THE BATTERY. STAND BACK.**
7. Start the vehicle and remove the cables in the reverse order of connection (the engine block (black) connection is the first to disconnect).

Check Mower Blades

Service Interval: Before each use or daily

1. Stop engine, wait for all moving parts to stop, and remove key. Engage parking brake.
2. Lift deck and secure in raised position as stated in the **Clean Grass Build-Up Under Deck** section.
3. Inspect blades and sharpen or replace as required.
4. Reinstall the blades (if they were removed) in the following order:
 - A. Install bushing through blade with bushing flange on bottom (grass) side of blade.

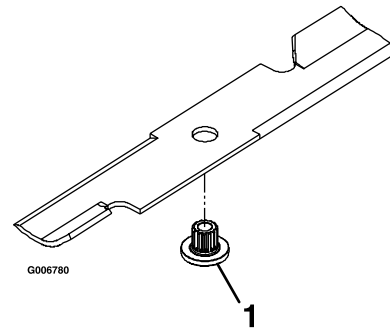

Figure 21

1. Install bushing in blade prior to installing bushing in spindle.

- B. Install bushing/blade assembly into spindle. Make sure the splines on the bushing are engaged in the spindle before tightening the bolt.

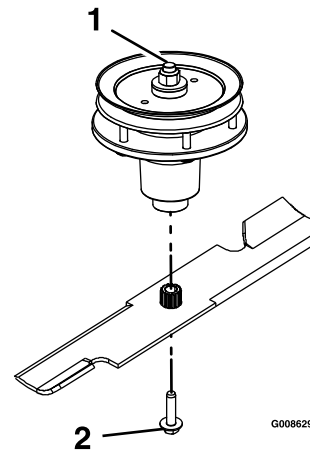

Figure 22

1. Use wrench here for blade installation:
LZZ-LP: This nut has been torqued to 90-110 ft-lb (122-149 N-m).
LZAS-LP: This nut has been torqued to 140-145 ft-lb (190-197 N-m)
2. Torque to 55-60 ft-lb (75-81 N-m) Apply lubricant to threads as needed to prevent seizing. Copper-based anti-seize preferable. Grease acceptable substitute.

- C. Apply lubricant to threads of blade bolt to prevent seizing. Copper-based anti-seize preferable. Grease acceptable substitute. Install blade bolt finger tight. Place wrench on the top spindle nut then torque the blade bolts to 55-60 ft-lb (75-81 N-m).

⚠ WARNING

Incorrect installation of the blade or components used to retain the blade can be dangerous. Failure to use all original components and assembled as shown could allow a blade or blade component to be thrown out from under the deck resulting in serious personal injury or death.

Always install the original Exmark blades, blade bushings, and blade bolts as shown.

Check Safety Interlock System

Service Interval: Before each use or daily

Note: To prevent engine cut-outs on rough terrain the seat kill switch has a 1/2 second delay.

1. Check starting circuit. Starter **should** crank with, parking brake **engaged**, PTO **disengaged** and motion control levers moved out in the **neutral lock** position. The operator does not need to be in the seat to start the engine.

Try to start with **operator in seat**, parking brake disengaged, PTO disengaged and motion control levers in the **neutral lock** position - starter **must not crank**.

Try to start with **operator in seat**, parking brake engaged, PTO **engaged** and motion control levers in the **neutral lock** position - starter **must not crank**.

Try to start with **operator in seat**, parking brake **engaged**, PTO **disengaged**, and the **left motion control lever in**, starter **must not crank**, repeat again with the **right lever in**, then with **both levers in** - starter **must not crank**.

2. Check the kill circuits. Run engine at one-third throttle, **disengage** parking brake and **raise off** of seat (but do not get off of machine) engine **must initiate shutdown** after approximately 1/2 second has elapsed (seat has time delay kill switch to prevent cut-outs on rough terrain).

Run engine at one-third throttle, **engage PTO** and **raise off** of seat (but do not get off of machine) engine **must initiate shutdown** after

one second has elapsed if the handles are in. The delay will be 1/2 second if the handles are out.

Run engine at one-third throttle, with brake disengaged, move levers in and raise off seat (but do not get off of machine) engine **must initiate shutdown** after 1/2 second has elapsed.

Again, run engine at one-third throttle, brake **engaged**, and move **left motion control lever in** - engine **must initiate shutdown** after 1/2 second has elapsed.

Repeat again moving the **right lever in**, then moving **both levers in** - engine **must initiate shutdown** after 1/2 second has elapsed whether operator is **on seat or not**.

Note: If machine does not pass any of these tests, do not operate. Contact your authorized **EXMARK SERVICE DEALER**.

Important: It is essential that operator safety mechanisms be connected and in proper operating condition prior to use for mowing.

Check Rollover Protections Systems (Roll Bar) Knobs

Service Interval: Before each use or daily

Check that both the mounting hardware and the knobs are in good working condition. Make sure the knobs are fully engaged with the ROPS in the raised position. The upper hoop of the roll bar may need to be pushed forward or pulled rearward to get both knobs fully engaged.

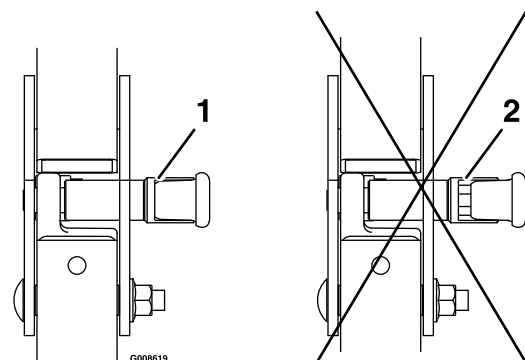

Figure 23

1. Engaged

2. Partially engaged — Do Not operate with ROPS in this condition.

Maintenance

Check Seat Belt

Service Interval: Before each use or daily

Visually inspect seat belt for wear, cuts, and proper operation of retractor and buckle. Replace before operating if damaged.

Check for Loose Hardware

Service Interval: Before each use or daily

1. Stop engine, wait for all moving parts to stop, and remove key. Engage parking brake.
2. Visually inspect machine for any loose hardware or any other possible problem. Tighten hardware or correct the problem before operating.

Service Air Cleaner

Service Interval: Every 250 hours—Replace the primary air cleaner element — check secondary air cleaner element; replace if dirty. (May need more often under severe conditions. See the Engine Owner's Manual for additional information.)

Every 500 hours—Replace the secondary air cleaner element (May need more often under severe conditions. See the Engine Owner's Manual for additional information.)

1. Stop engine, wait for all moving parts to stop, and remove key. Engage parking brake.
2. See the Engine Owner's Manual for maintenance instructions.

Change Engine Oil

Service Interval: After the first 5 hours

Every 100 hours/Yearly (whichever comes first) (May need more often under severe conditions.)

1. Stop engine, wait for all moving parts to stop, and remove key. Engage parking brake.
2. Drain oil while engine is warm from operation.
3. The oil drain hose is located on right hand side of engine at the rear. Place pan under machine to catch oil. Remove plug from end of drain hose. Allow oil to drain and replace oil drain plug. Torque plug to 20-24 ft-lb.
4. Replace the oil filter every other oil change. Clean around oil filter and unscrew filter to remove. Before reinstalling new filter, apply a thin coating of oil on the surface of the rubber seal. Turn filter clockwise until rubber seal contacts the filter adapter then tighten filter an additional 1/2 to 3/4 turn.
5. Clean around oil fill cap and remove cap. Fill to specified capacity and replace cap.
6. Use oil recommended in engine owner's manual. **Do Not** overfill. Start the engine and check for leaks.
7. Wipe up any spilled oil from engine deck mounting surfaces.

Check Hydraulic Oil Level

Service Interval: Every 50 hours

1. Stop engine and wait for all moving parts to stop. Engage parking brake.
2. Wait until the unit cools before checking the hydraulic oil.
3. Slide the seat all the way forward to access the caps on the LH and RH hydro drives.
4. Clean the area around hydraulic reservoir cap and remove cap.
5. Wipe the dipstick clean and re-insert the cap back into the hydro. Lightly tighten the cap.
6. Remove the cap again and check the level of the oil on the dipstick. See Figure 24 for oil levels.

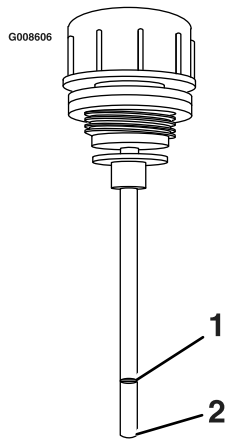

Figure 24

1. Full
2. Add

Note: The oil level on the dipstick will be incorrect if the oil is checked when the unit is hot.

7. If the dipstick oil level is at the “add” mark add Exmark Premium Hydro oil.
8. Replace hydraulic reservoir cap and tighten until snug. **Do Not overtighten.**

Check Tire Pressures

Service Interval: Every 50 hours

1. Stop engine, wait for all moving parts to stop, and remove key. Engage parking brake.
2. Check tire pressure in drive tires.
3. Inflate drive tires to 13 psi (90 kPa).
4. Semi-pneumatic caster tires Do Not need to be inflated.

Note: Do Not add any type of tire liner or foam fill material to the tires. Excessive loads created by foam filled tires may cause failures to the hydro drive system, frame, and other components. Foam filling tires will void the warranty.

Check Condition Of Belts

Service Interval: Every 50 hours

1. Stop engine, wait for all moving parts to stop, and remove key. Engage parking brake.
2. Remove left and right belt shields on deck and lift up floor pan to inspect deck drive belt.
3. Check under machine to inspect the pump drive belt.

Note: No adjustments are required for belt tension.

Lubricate Grease Fittings

Note: See chart for service intervals.

1. Stop engine, wait for all moving parts to stop, and remove key. Engage parking brake.
2. Lubricate fittings with one to two pumps of NGLI grade #2 multi-purpose gun grease.

Refer to the following chart for fitting locations and lubrication schedule.

Lubrication Chart			
Fitting Locations	Initial Pumps	Number of Places	Service Interval
1. Deck and Pump Idler Pivots	1	2	Yearly
2. Front Caster Pivots	*0	2	*Yearly

* See step 3 for special lubrication instructions on the front caster pivots.

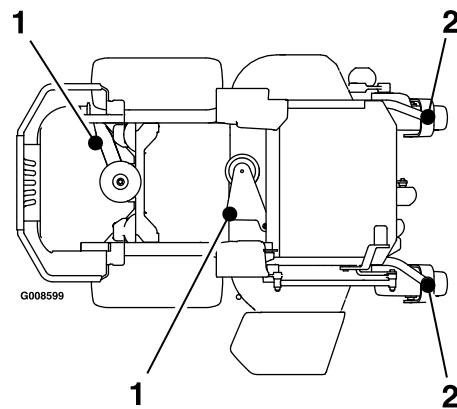

3. Lubricate front caster pivots once a year. Remove hex plug and cap. Thread grease zerk in hole and pump with grease until it oozes out around top bearing. Remove grease zerk and thread plug back in. Place cap back on.

Lubricate Caster Wheel Hubs

Service Interval: As required

1. Stop engine, wait for all moving parts to stop, and remove key. Engage parking brake.

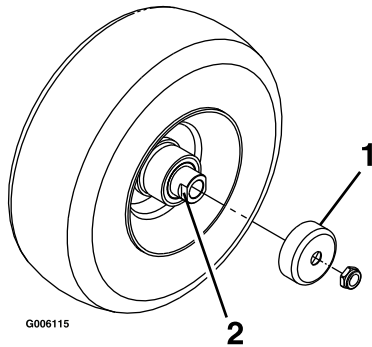

Figure 25

1. Seal guard
2. Spacer nut with wrench flats

2. Remove caster wheel from caster forks.
3. Remove seal guards from the wheel hub.
4. Remove one of the spacer nuts from the axle assembly in the caster wheel. Note that thread locking adhesive has been applied to lock the spacer nuts to the axle. Remove the axle (with the other spacer nut still assembled to it) from the wheel assembly.
5. Pry out seals, and inspect bearings for wear or damage and replace if necessary.
6. Pack the bearings with a NGLI grade #1 multi-purpose grease.
7. Insert one bearing, one new seal into the wheel.
Note: Seals (Exmark P/N 103-0063) must be replaced.
8. If the axle assembly has had both spacer nuts removed (or broken loose), apply a thread locking adhesive to one spacer nut and thread onto the axle with the wrench flats facing outward. Do Not thread spacer nut all of the way onto the end of the axle. Leave approximately 1/8 inch (3 mm) from the outer surface of the spacer nut to the end of the axle inside the nut.
9. Insert the assembled nut and axle into the wheel on the side of the wheel with the new seal and bearing.
10. With the open end of the wheel facing up, fill the area inside the wheel around the axle full of NGLI grade #1 multi-purpose grease.
11. Insert the second bearing and new seal into the wheel.
12. Apply a thread locking adhesive to the 2nd spacer nut and thread onto the axle with the wrench flats facing outward.

13. Torque the nut to 75-80 in-lb (8-9 N-m), loosen, then re-torque to 20-25 in-lb (2-3 N-m). Make sure axle does not extend beyond either nut.
14. Reinstall the seal guards over the wheel hub and insert wheel into caster fork. Reinstall caster bolt and tighten nut fully.

Important: To prevent seal and bearing damage, check the bearing adjustment often. Spin the caster tire. The tire should not spin freely (more than 1 or 2 revolutions) or have any side play. If the wheel spins freely, adjust torque on spacer nut until there is a slight amount of drag. Reapply thread locking adhesive.

Lubricate Brake Handle Pivot

Service Interval: Every 200 hours

1. Stop engine, wait for all moving parts to stop, and remove key. Engage parking brake.
2. Lubricate brake handle pivot with a spray type lubricant or light oil.

Lubricate Deck Lift Pivot

Service Interval: Every 100 hours

1. Stop engine, wait for all moving parts to stop, and remove key. Engage parking brake.
2. Lubricate deck lift pivot with a spray type lubricant or light oil.

Check Spark Plugs

Service Interval: Every 200 hours

Remove spark plugs, check condition and reset gaps, or replace with new plugs. Set the spark plug gap to .025 inch. See Engine Owner's Manual.

Check LPG Tank

Service Interval: Before each use or daily

Check the LPG tank and components for wear or leaks. Follow all the inspection checks as specified in the **Inspection** section in Safety.

Check LPG Fuel Delivery System

Service Interval: Every 40 hours

Check the entire LPG fuel delivery system for damage or deterioration. Follow all the inspection checks as specified in the **Inspection** section in Safety.

Change LPG Tank

Service Interval: As required

Change the LPG tank outdoors in a well ventilated area.

1. Stop the machine on level ground, disengage the PTO, and engage the parking brake.
2. Close the fuel valve on the tank.
3. Purge all vapors from the hose, by running the engine until it stops, turn key to “OFF” and remove it from the ignition.
4. Carefully disconnect the LPG fuel hose.
5. Unlatch the cylinder brackets and remove the tank.

⚠ WARNING

Fuel system components are under high pressure. The use of damaged or improper components can cause system failure, fuel leakage, and possible explosion, which may result in serious injury or death.

- **Do Not attempt to repair or modify the valves, fittings, or other tank components.**
- **ONLY use the Exmark approved LPG tank, fittings, and hoses that were designed for your mower.**

6. Inspect the filled tank valve and fitting openings for dirt, debris, or damage.
7. Inspect the tank hose connection fitting for damaged or missing o-rings.
8. Make sure the replacement tank type and size match the tank specification decal.
9. Align the center hole over the mounting pin that points straight up on the mower as shown in Figure 26.

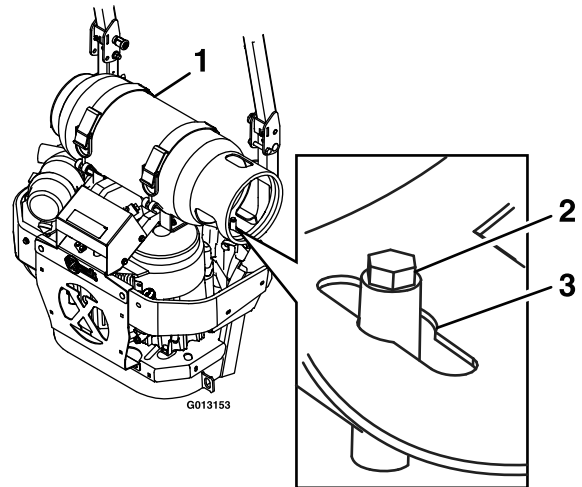

Figure 26

- | | |
|-----------------|----------------|
| 1. Tank collar | 3. Center hole |
| 2. Mounting pin | |

Important: Valves and gauges may not function properly if the LPG tank is not installed correctly.

10. Latch the brackets and make sure the tank is securely fastened to the mower.
11. Carefully connect the fuel hose. Make sure the hose is not kinked.
12. Slowly open the fuel valve to equalize the pressure in the tank. If the fuel valve is opened too quickly, the pressure relief valve is equipped with a back pressure check valve that will shut off the fuel supply. If this happens, close the fuel valve completely and wait five seconds. Slowly open the fuel valve.
13. Check for leaks as described in the **Inspection** section in Safety.

Change Hydraulic System Filter and Fluid

Service Interval: Every 500 hours

Note: Only use Exmark Hydro Filter—Part No. 116-0164 for summer or winter.

1. Stop engine, wait for all moving parts to stop, and remove key. Engage parking brake.
2. Raise the rear of machine up and support with jack stands (or equivalent support) just high enough to allow drive wheels to turn freely.

⚠ CAUTION

Raising the mower deck for service or maintenance relying solely on mechanical or hydraulic jacks could be dangerous. The mechanical or hydraulic jacks may not be enough support or may malfunction allowing the unit to fall, which could cause injury.

Do Not rely solely on mechanical or hydraulic jacks for support. Use adequate jack stands or equivalent support.

3. Remove the pump drive belt.
4. Place a catch pan under the hydro.
5. Carefully clean area around the filters. It is important that no dirt or contamination enter the hydraulic system.
6. Using a socket, unscrew filters to remove and allow oil to drain.
7. Before installing the new filters, apply a thin coat of Exmark Premium Hydro oil on the surface of the two rubber seals.
8. Install the new filters and torque to 14 ft-lb (19 N-m).
9. Fill the hydraulic system as stated in **Check Hydraulic Oil Level** section.

Exmark Premium Hydro Oil is recommended. Refer to the chart for an acceptable alternative:

Hydro Oil	Change Interval
Exmark Premium Hydro Oil (Preferred)	500 Hours
Mobil 1 15W50	250 Hours

10. Remove the catch pan and properly dispose of hydro oil and filter according to local codes.
11. Re-install the pump drive belt.
12. Start engine and move throttle control ahead to full throttle position. Move the speed control levers to the full speed and run for one minute. Shut down the machine, allow the hydros to cool and recheck oil level.
13. Remove the jack stands.

Note: Do Not change the hydraulic system oil (except for what can be drained when changing filter), unless it is felt the oil has been contaminated or been extremely hot.

Changing oil unnecessarily could damage hydraulic system by introducing contaminants into the system.

Wheel Hub - Slotted Nut Torque Specification

**Service Interval: After the first 100 hours
Every 500 hours thereafter**

Torque the slotted nut to 211-260 ft-lb (286-352 N-m).

Note: Do Not use anti-seize on wheel hub.

Thread Locking Adhesives

Thread locking adhesives such as “Loctite 242” or “Fel-Pro, Pro-Lock Nut Type” are used on the following fasteners:

- ROPS spring pin housing.
- Hydro pump control arm, linkage bolt, and attachment bolt.
- Hydro cooling fan screw.
- Hydro park brake cable anchor mounting bolt
- Sheave and clutch retaining bolt in the end of engine crankshaft.

Thread locking adhesives are required for some hardware on engines — see the Engine manual.

Copper-Based Anti-seize

Copper-based anti-seize is used in the following location:

On threads of Blade Bolts. See **Check Mower Blades** section.

Dielectric Grease

Dielectric grease is used on all blade type electrical connections to prevent corrosion and loss of contact.

LPG Regulator

No adjustments necessary. If the engine is not running properly, contact an Authorized Service Dealer

Adjustments

Note: Disengage PTO, shut off engine, wait for all moving parts to stop, engage parking brake, and remove key before servicing, cleaning, or making any adjustments to the unit.

⚠ CAUTION

Raising the mower deck for service or maintenance relying solely on mechanical or hydraulic jacks could be dangerous. The mechanical or hydraulic jacks may not be enough support or may malfunction allowing the unit to fall, which could cause injury.

Do Not rely solely on mechanical or hydraulic jacks for support. Use adequate jack stands or equivalent support.

6. Insert the height adjustment pin into the 3 inch (7.6 cm) cutting height location.
7. Release the transport lock and allow the deck to lower to the cutting height.
8. Raise the discharge deflector.
9. Measure from the level surface to the front tip of the center blade. The measurement should read 3 inches (7.6 mm).

Note: In most conditions, the back tips on the side blades should be adjusted 1/4 inch (6.4 mm) higher than the front.

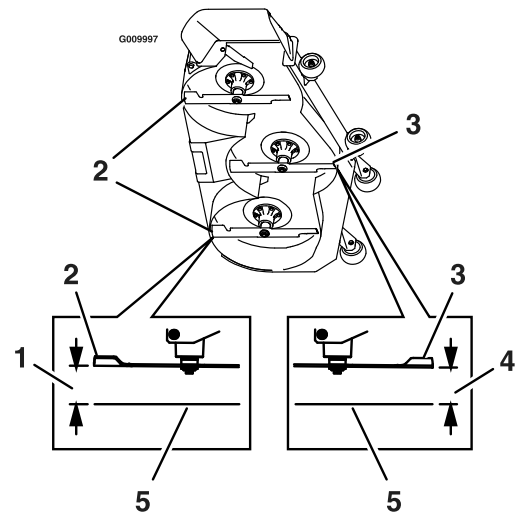

Figure 28

- | | |
|--------------------------|----------------------|
| 1. 3 1/4 inches (8.3 cm) | 4. 3 inches (7.6 cm) |
| 2. Back blade tip | 5. Level surface |
| 3. Front blade tip | |

Deck Leveling

1. Position the mower on a flat surface.
2. Stop engine, wait for all moving parts to stop, and remove key. Engage parking brake.
3. Check the tire pressure in the drive tires. Proper inflation pressure for tires is 13 psi (90 kPa). Adjust if necessary.
4. Position the transport lock in the latching position.
5. Push the foot pedal all the way forward and the deck will latch at the 5 1/2 inch (14 cm) transport position (Figure 27).

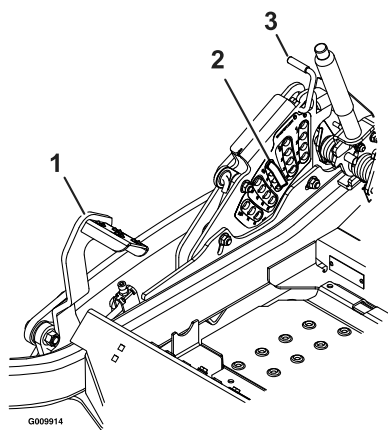

Figure 27

- | | |
|----------------------|-------------------|
| 1. Foot lever | 3. Transport lock |
| 2. Height of cut pin | |

10. For LZZ-LP Units: Loosen the jam nuts on the top of each deck link. Fine tune the adjuster on the front deck lift assembly by turning it to get 3 inch (7.6 mm) height (see Figure 29).

To increase the height, turn the adjuster clockwise; to decrease, turn counterclockwise.

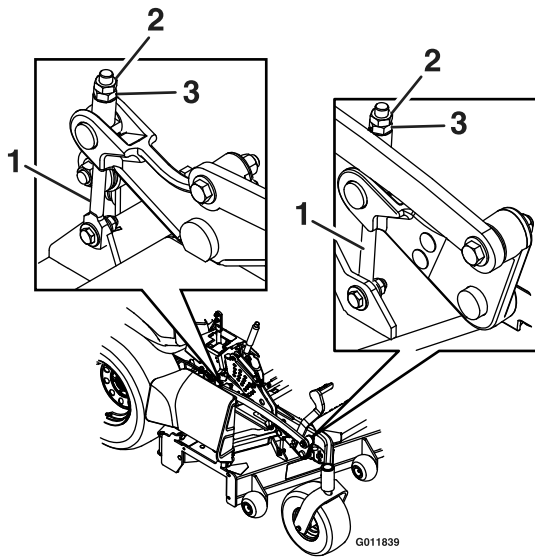

Figure 29

- | | |
|------------------|-------------|
| 1. Adjuster link | 3. Adjuster |
| 2. Jam nut | |

For LZAS-LP Units: Loosen the whizlock nut on the side of the yoke and the jam nut on top. Fine tune the screw adjuster by turning it to get 3 inch (7.6 mm) height (see Figure 30).

To increase the height, turn the adjuster screw clockwise; to decrease, turn counterclockwise.

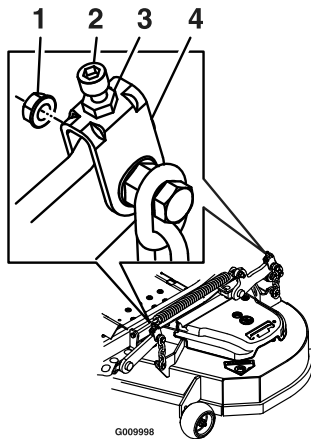

Figure 30

- | | |
|-------------------|------------|
| 1. Whizlock nut | 3. Jam nut |
| 2. Adjuster screw | 4. Yoke |

11. The back tips of the side blades should measure 3 1/4 inches (8.3 cm). Fine tune rear adjusters as required.
12. Re-measure until all four sides are the correct height. Tighten all the nuts on the deck lift arm assemblies.
13. Lower discharge deflector.

14. If the four deck links do not have enough adjustment to achieve accurate cut height with the desired rake, the single point adjustment can be utilized to gain more adjustment (see Figure 31).

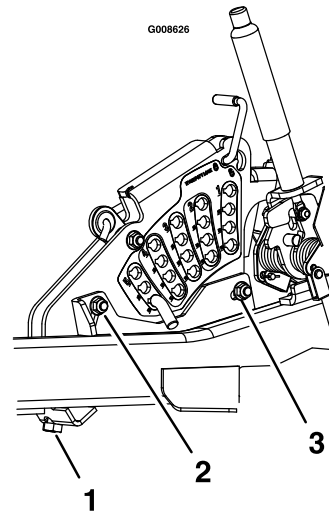

Figure 31

- | |
|--|
| 1. Single point height adjustment bolt |
| 2. Front height-of-cut plate mounting bolt |
| 3. Rear height-of-cut plate mounting bolt |

15. To adjust the single point system, first loosen the front and rear height-of-cut plate mounting bolts.
16. If the deck is too low, tighten the single point adjustment bolt by rotating it clockwise. If the deck is too high, loosen the single point adjustment bolt by rotating it counterclockwise.

Note: Loosen or tighten the single point adjustment bolt enough to move the height-of-cut plate mounting bolts at least 1/3 the length of the available travel in their slots. This will regain some up and down adjustment on each of the four deck links.

17. Re-tighten front and rear height-of-cut plate mounting bolts.

Important: Torque the front and rear height-of-cut plate mounting bolts to 27-33 ft-lb (37-45 N-m).

18. Repeat steps 9 through 13.

Pump Drive Belt Tension

Self-tensioning - No adjustment necessary.

Deck Belt Tension

Self-tensioning - No adjustment necessary.

Adjusting the Parking Brake

**Service Interval: After the first 100 hours
Every 500 hours thereafter**

Check to make sure brake is adjusted properly. This procedure must be followed after the first 100 hours or when a brake component has been removed or replaced.

1. Drive the machine onto a level surface.
2. Disengage the blade control switch (PTO), move the motion control levers to the neutral locked position and set the parking brake.
3. Stop the engine, wait for all moving parts to stop, and remove the key.
4. Raise the back of the machine up and support the machine with jack stands.

⚠ CAUTION

Raising the mower deck for service or maintenance relying solely on mechanical or hydraulic jacks could be dangerous. The mechanical or hydraulic jacks may not be enough support or may malfunction allowing the unit to fall, which could cause injury.

Do Not rely solely on mechanical or hydraulic jacks for support. Use adequate jack stands or equivalent support.

5. Remove the rear tires from the machine.
6. Remove any debris from the brake area.
7. Rotate the drive wheel release handle to the “released” position. Refer to the **Drive Wheel Release Valves** section in Operation.
8. Disengage the park brake.
9. Hold the threaded rod end with a tool and loosen the lock nut away from the standard nut (see Figure 32). Do Not allow the cable to turn when the nuts are being loosened.

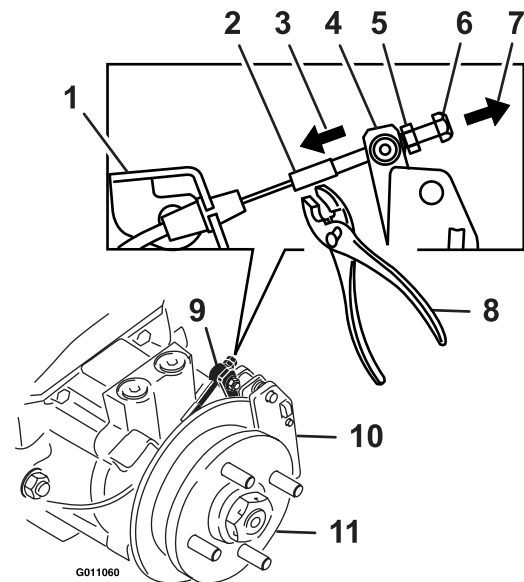

Figure 32

Left Hand Brake Shown

- | | |
|--|---|
| 1. Cable anchor | 7. Pull cable threaded rod this direction |
| 2. Threaded rod | 8. Hold threaded rod here |
| 3. Push lever this direction | 9. Swivel (pivot head) |
| 4. Caliper lever arm | 10. Caliper |
| 5. Standard nut (shown against swivel) | 11. Hub |
| 6. Lock nut | |

10. Remove all slack from cable by pulling on the caliper lever arm with a medium amount of force. Using hands and fingers only, push the caliper lever arm to engage the brake pads on the rotor until the lever stops. While holding the lever at the stopped position, use the other hand or fingers to pull the slack out of the cable threaded end through the swivel. Spin the standard nut against the swivel (see Figure 32).

Note the order of the standard nut and lock nut (no nut on the cable anchor side of the swivel).

11. Release the caliper lever and cable. Turn the wheel hub by hand in both directions relative to the caliper; slight drag of the caliper pad on the wheel hub is desired.
12. If there is no movement between the hub and the caliper then back off the standard nut one turn from the swivel and repeat step 11 (drive release valves must be in the “released” position on the hydros).
13. If the hub moves very freely relative to the caliper, then tighten the standard nut one turn against the swivel and repeat step 11.

Maintenance

14. Once step 11 is achieved, hold the threaded rod end with a tool and tighten the lock nut against the standard nut. Do Not allow the cable to turn when the nuts are tightened.
15. After adjusting the brakes on both sides of the mower, cycle the brake handle a minimum of six times to allow the cable to seat into the sheath and mounting tabs.
16. Readjust both brakes following the procedure in steps 10 through 14.
17. If a brake component has been removed or replaced, see the steps below; otherwise proceed to step 18.

Burnishing the Brake Procedure:

- A. Clear the area of any flammable material before starting the burnishing process.
- B. Rotate the drive wheel release handle to the “operating” position. Refer to the Drive Wheel Release Valves section in Operation.
- C. Apply the park brake.
- D. Install a 1/2 x 6 inch (approx.) rod or bolt through the 2 inch height of cut hole (see Figure 33).

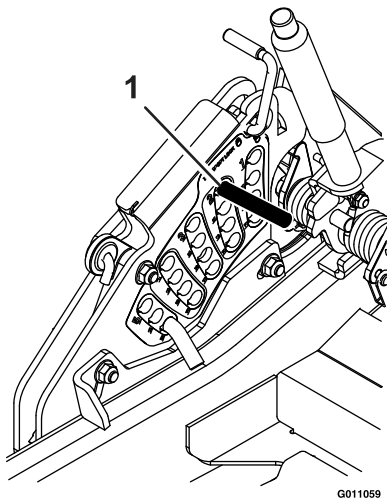

Figure 33

1. 2 inch height of cut location

- E. Start the mower while in the operator position.

⚠ WARNING

Engine must be running and drive wheels must be turning so park brake adjustment can be performed. Contact with moving parts or hot surfaces may cause personal injury.

Keep fingers, hands, and clothing clear of rotating components and hot surfaces.

- F. Release the park brake so the handle rests on the 1/2 x 6 inch rod or bolt.
 - G. Move the throttle to high idle.
 - H. Move both motion control levers to the full forward position and hold for 15 seconds.
 - I. Move both motion control levers to the full reverse position and hold for 15 seconds.
 - J. Turn off the engine and completely release the park brake by removing the 1/2 x 6 inch rod or bolt.
 - K. Allow the hubs to cool until they are cool enough to safely touch.
 - L. Rotate the drive wheel release handle to the “released” position. Refer to the **Drive Wheel Release Valves** section in Operation.
 - M. Readjust both brakes following the procedure in steps 10 through 14.
18. Rotate the drive wheel release handle to the “operating” position. Refer to the **Drive Wheel Release Valves** section in Operation.
 19. Install the rear tires and torque lug nuts to 90-95 ft-lb (122-129 N-m).
 20. Remove jack stands.

Electric Clutch Adjustment

No adjustment necessary; however some later model year units have been built with clutches that contain a brake shim. When the clutch brake has worn to the point where the clutch no longer engages consistently, the shim can be removed to extend the clutch life.

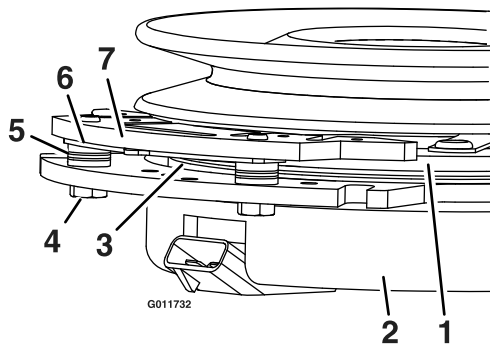

Figure 34

- | | |
|------------------------|-----------------|
| 1. Armature | 5. Brake spacer |
| 2. Field shell | 6. Re-gap shim |
| 3. Rotor | 7. Brake pole |
| 4. Brake mounting bolt | |

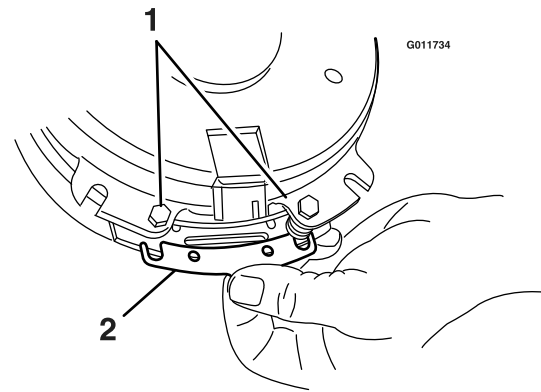

Figure 35

- | | |
|------------------------|---------|
| 1. Brake mounting bolt | 2. Shim |
|------------------------|---------|

Removing the Shim:

1. Stop engine, wait for all moving parts to stop, and remove key. Engage parking brake. Allow the machine to cool completely before starting these instructions.
2. Using a pneumatic line, blow out any debris from under the brake pole and around the brake spacers.
3. Check the condition of the wire harness leads, connectors, and terminals. Clean or repair as necessary.
4. Verify that 12V is present at the clutch connector when the PTO switch is engaged.
5. Measure the gap between the rotor and armature. If the gap is greater than .04 inch (1 mm), proceed with the following steps:
 - A. Loosen both brake mounting bolts one-half to one full turn (see Figure 35).
 - B. Using needle nose pliers, or by hand, take hold of the tab and remove the shim (Do Not discard the shim until proper clutch function has been confirmed).
 - C. Using a pneumatic line, blow out any debris from under the brake pole and around the brake spacers.
 - D. Re-torque each bolt (M6 x 1) to 10 ft-lb (13 N-m) +/-0.5 ft-lb (0.7 N-m).
 - E. Using a 0.010 inch thick feeler gauge, verify that a gap is present between the rotor and armature face on both sides of the brake pole as shown. (Due to the way the rotor and armature faces wear (peaks and valleys) it is sometimes difficult to measure the true gap.)

Note: Do Not remove the brake pole from the field shell/armature. The brake pole has worn to match the armature and needs to continue to match after the shim is removed to ensure proper brake torque.

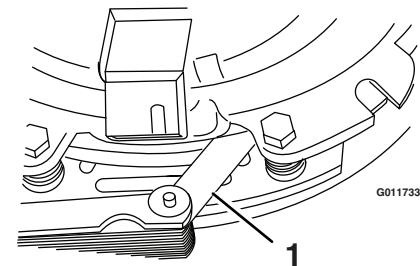

Figure 36

- | |
|-----------------|
| 1. Feeler gauge |
|-----------------|

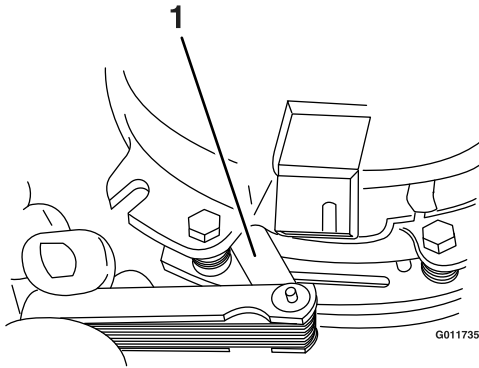

Figure 37

1. Feeler gauge

- If the gap is less than 0.010 inch, then reinstall the shim and reference the **Troubleshooting** section.
- If the gap is sufficient, proceed to the safety check in step F.

F. Perform the following safety check:

- a. Sit on the seat and start the engine.
- b. Make sure the blades Do Not engage with the PTO switch “off” and the clutch disengaged.

If the clutch does not disengage, reinstall the shim and reference the **Troubleshooting** section.

- c. Engage and disengage the PTO switch ten consecutive times to ensure the clutch is functioning properly. If the clutch does not engage properly, reference the **Troubleshooting** section.

Motion Control Linkage Adjustment

Located on either side of the fuel tank, below the seat are the pump control linkages. Rotating the pump linkage with a 1/2 inch wrench allows fine tuning adjustments so that the machine does not move in neutral. Any adjustments should be made for neutral positioning only.

⚠ WARNING

Engine must be running and drive wheels must be turning so motion control adjustment can be performed. Contact with moving parts or hot surfaces may cause personal injury.

Keep fingers, hands, and clothing clear of rotating components and hot surfaces.

1. Prior to starting the engine, push the deck lift pedal and remove the height of cut pin. Lower deck to the ground.
2. Raise the rear of machine up and support with jack stands (or equivalent support) just high enough to allow drive wheels to turn freely.
3. Remove the electrical connection from the seat safety switch, located under the bottom cushion of the seat. The switch is a part of the seat assembly.
4. **Temporarily** install a jumper wire across the terminals in the connector of the main wiring harness.
5. Start engine. **Brake must be engaged and motion control levers out to start engine. Operator does not have to be in the seat because of the jumper wire being used.** Run engine at full throttle and release brake.
6. Run the unit at least 5 minutes with the drive levers at full forward speed to bring hydraulic oil up to operating temperature.

Note: The motion control lever needs to be in neutral while making any necessary adjustments.

7. Bring the motion control levers into the neutral position. Adjust pump control rod lengths by rotating the double nuts on the rod in the appropriate direction until the wheels slightly creep in reverse (Figure 38). Move the motion control levers to the reverse position and while applying slight pressure to the lever allow the reverse indicator springs to bring the levers back to neutral. The wheels must stop turning or slightly creep in reverse.

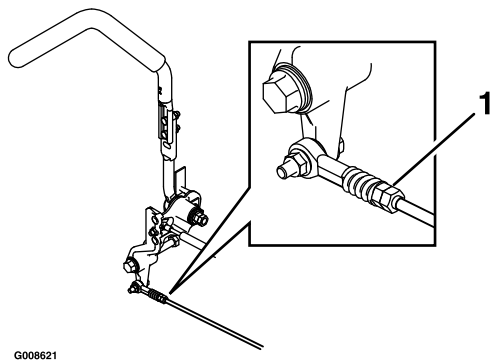

Figure 38

1. Double nuts

8. Shut off unit. Remove jumper wire from wire harness and plug connector into seat switch.
9. Remove the jack stands.
10. Raise the deck and re-install the height of cut pin.
11. Check that the machine does not creep in neutral with the park brakes disengaged.

Motion Control Damper Adjustment

The top damper mounting bolt can be adjusted to obtain a more desired motion control lever resistance. See Figure 39 for mounting options.

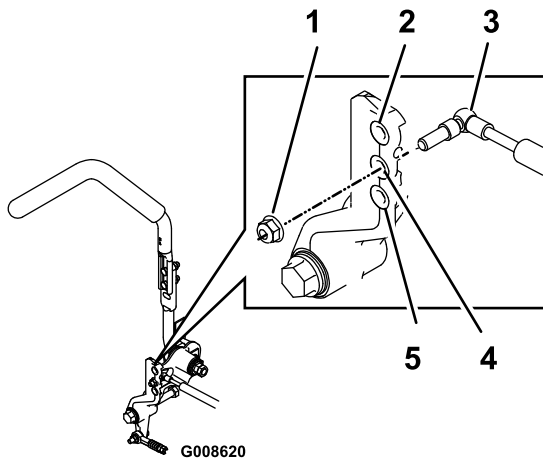

Figure 39

RH Motion Control Shown

1. Torque nyloc nut to 200 in-lb (16.7 ft-lb). Bolt must protrude past end of nyloc nut after torque. A T-40 Torx bit will be necessary to hold the stud from turning.
2. Most resistance (firmest feel)
3. Damper
4. Medium resistance (medium feel)
5. Least resistance (softest feel)

Motion Control Neutral Lock Pivot Adjustment

The flanged nut can be adjusted to obtain a more desired motion control lever resistance (Figure 40).

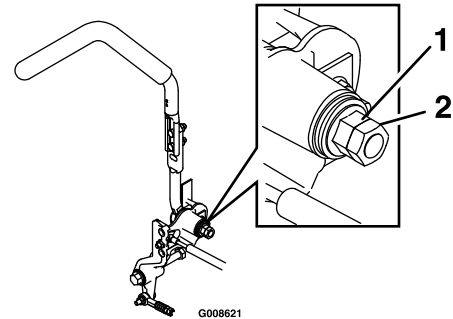

Figure 40

1. Flanged nut
2. Jam nut

1. Loosen the jam nut.
2. Tighten or loosen the flanged nut to the desired feel.

For more resistance, tighten the flanged nut.
For less resistance, loosen the flanged nut
3. Tighten jam nut.

Motion Control Handle Adjustment

Adjusting the height:

The motion control levers can be adjusted higher or lower for maximum operator comfort.

1. Remove the two bolts holding the control lever to the control arm shaft (Figure 41).

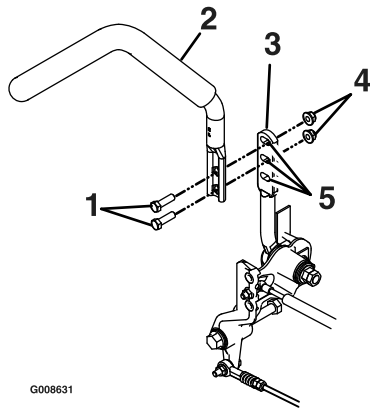

Figure 41

- | | |
|----------------------|------------------|
| 1. Bolts | 4. Nuts |
| 2. Control lever | 5. Slotted holes |
| 3. Control arm shaft | |

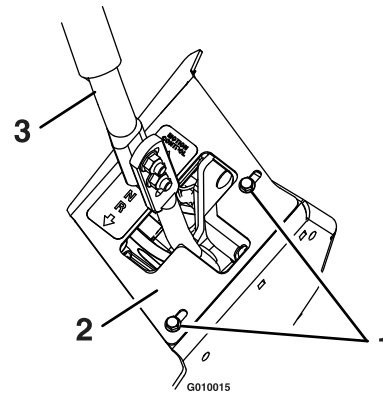

Figure 42

RH Motion Control Shown

- | | |
|----------------|-------------------------|
| 1. Screw | 3. Motion control lever |
| 2. Cover plate | |

2. Move the control lever to the next set of holes. Secure the lever with the two bolts.
3. Repeat the adjustment for the opposite control lever.

Adjusting the Tilt

The motion control levers can be tilted fore or aft for maximum operator comfort.

1. Loosen the upper bolt holding the control lever to the control arm shaft.
2. Loosen the lower bolt just enough to pivot the control lever fore or aft Figure 41. Tighten both bolts to secure the control in the new position.
3. Repeat the adjustment for the opposite control lever.

Motion Control Full Forward Tracking Adjustment

If the machine travels or pulls to one side when the motion control levers are in the full forward position, adjust the cover plates.

1. Loosen the screws on a cover plate (see Figure 42).
2. Slide the cover plate backward or forward to adjust the travel of the lever and tighten the screws.
3. Drive the machine and check the full forward tracking.
4. Repeat steps 1 through 3 until desired tracking is obtained.

Caster Pivot Bearings Pre-Load Adjustment

Remove dust cap from caster and tighten nyloc nut until washers are flat and back off 1/4 of a turn to properly set the pre-load on the bearings. If disassembled, make sure the spring disc washers are reinstalled as shown in Figure 43.

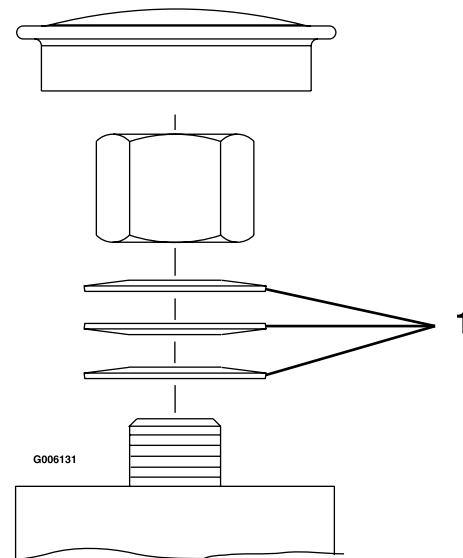

Figure 43

1. Spring disc washers

Cleaning

Clean Engine and Exhaust System Area

Service Interval: Before each use or daily (May be required more often in dry or dirty conditions.)

⚠ CAUTION

Excessive debris around engine cooling air intake and exhaust system area can cause engine, exhaust area, and hydraulic system to overheat which can create a fire hazard.

Clean all debris from engine and exhaust system area.

1. Stop engine, wait for all moving parts to stop, and remove key. Engage parking brake.
2. Clean all debris from rotating engine air intake screen, around engine shrouding, and exhaust system area.
3. Wipe up any excessive grease or oil around the engine and exhaust system area

Remove Engine Shrouds and Clean Cooling Fins

Service Interval: Every 100 hours

1. Stop engine, wait for all moving parts to stop, and remove key. Engage parking brake.
2. Remove cooling shrouds from engine and clean cooling fins. Also clean dust, dirt and oil from external surfaces of engine which can cause inadequate cooling.
3. Make sure cooling shrouds are reinstalled. Operating the engine without cooling shrouds will cause engine damage due to overheating.

Clean Hydro Fan Cooling Fins

Service Interval: Before each use or daily

Removing debris from the hydro fan cooling fins will allow the hydro system to run cooler and improve the life of the hydro system.

1. Stop engine, wait for all moving parts to stop, and remove key. Engage parking brake.
2. Slide seat all the way forward.
3. Remove accumulated debris from the hydro fan cooling fins.

Clean Debris From Machine

Service Interval: Before each use or daily

1. Stop engine, wait for all moving parts to stop, and remove key. Engage parking brake.
2. Clean off any oil, debris, or grass build-up on the machine and cutting deck, especially under deck belt shields, around the fuel tank, around engine and exhaust area.

Clean Grass Build-Up Under Deck

Service Interval: Before each use or daily

1. Stop engine, wait for all moving parts to stop, and remove key. Engage parking brake.
2. Raise deck to the transport (5 1/2 inch (14 cm) cutting height) position. Lift the front of unit and support unit using jack stands or equivalent support.

⚠ CAUTION

Raising the mower deck for service or maintenance relying solely on mechanical or hydraulic jacks could be dangerous. The mechanical or hydraulic jacks may not be enough support or may malfunction allowing the unit to fall, which could cause injury.

Do Not rely solely on mechanical or hydraulic jacks for support. Use adequate jack stands or equivalent support.

3. Clean out any grass build-up from underside of deck and in discharge deflector.

Waste Disposal

Motor Oil Disposal

Engine oil and hydraulic oil are both pollutants to the environment. Dispose of used oil at a certified recycling center or according to your state and local regulations.

Battery Disposal

⚠ DANGER

Battery electrolyte contains sulfuric acid, which is poisonous and can cause severe burns. Swallowing electrolyte can be fatal or if it touches skin can cause severe burns.

- **Wear safety glasses to shield eyes, and rubber gloves to protect skin and clothing when handling electrolyte.**
- **Do Not swallow electrolyte.**
- **In the event of an accident, flush with water and call a doctor immediately.**

Federal law states that batteries should not be placed in the garbage. Management and disposal practices must be within relevant federal, state, or local laws.

If a battery is being replaced or if the unit containing the battery is no longer operating and is being scrapped, take the battery to a local certified recycling center. If no local recycling is available return the battery to any certified battery reseller.

Troubleshooting

Important: It is essential that all operator safety mechanisms be connected and in proper operating condition prior to mower use.

When a problem occurs, do not overlook the simple causes. For example: starting problems could be caused by an empty fuel tank.

The following table lists some of the common causes of trouble. Do not attempt to service or replace major items or any items that call for special timing of adjustment procedures (such as valves, governor, etc.). Have this work done by your **Engine Service Dealer**.

Note: When disconnecting electrical connectors DO NOT pull on the wires to separate the connectors.

Problem	Possible Cause	Corrective Action
Starter does not crank	<ol style="list-style-type: none"> 1. PTO is engaged. 2. Parking brake is not engaged. 3. Drive levers are not in neutral lock position. 4. Battery does not have a full charge. 5. Electrical connections are corroded, loose or faulty. 6. Fuse is blown. 7. Relay or switch is defective. 8. Faulty module. 	<ol style="list-style-type: none"> 1. Disengage the PTO. 2. Set the parking brake. 3. Ensure the drive levers are in the neutral lock position. 4. Charge the battery. See Check Battery Charge and Recommended Jump Starting Procedure sections in Maintenance. 5. Check the electrical connections for good contact. Clean connector terminals thoroughly with electrical contact cleaner, apply dielectric grease and reconnect. 6. Replace the blown fuse. 7. Contact an Authorized Service Dealer. 8. Replace module.
Engine will not start, starts hard, or fails to keep running	<ol style="list-style-type: none"> 1. Engine oil level is low. 2. LPG tank is overfilled. 3. Oil level in the crankcase is low. 4. LPG tank is not an Exmark approved vapor tank. 5. Engine is flooded. 6. Oil pressure switch or fuel shut-off solenoid malfunction. 7. Connection to the LPG tank is loose. 8. LPG fuel tank is empty or very low. 9. Fuel valve is closed. 10. Fuel valve opened to fast. 11. LPG tank is not installed properly. 12. LPG tank components or hoses are dirty or damaged. 13. The throttle is not in the correct position. 14. Air cleaner is dirty. 	<ol style="list-style-type: none"> 1. Check and add oil if necessary. 2. Take tank to an approved LPG provider to bleed off some fuel. 3. Add oil to the crankcase. 4. Remove tank and replace with an Exmark approved LPG vapor tank. 5. Shut off fuel valve. Let unit set for 15-30 minutes. With the valve still off and the throttle in the "SLOW" position, start the unit. Once the engine attempts to start, slowly open the fuel valve. 6. Contact an Authorized Service Dealer. 7. Hand-tighten connector to tank. 8. Replace the LPG fuel tank. 9. Open the fuel valve. 10. Open the fuel valve slowly to equalize pressure in the tank(s). 11. Reinstall the LPG tank. 12. Replace LPG tank components or hoses. 13. Be sure the throttle control is in the "SLOW" position. 14. Clean or replace the air cleaner element.

Troubleshooting

Problem	Possible Cause	Corrective Action
	15. Seat switch is not functioning properly. 16. Electrical connections are corroded, loose or faulty. 17. Relay or switch is defective. 18. Faulty spark plug. 19. Spark plug wire is not connected. 20. Faulty module.	15. Check the seat switch indicator. Replace seat if needed. 16. Check the electrical connections for good contact. Clean connector terminals thoroughly with electrical contact cleaner, apply dielectric grease and reconnect. 17. Contact an Authorized Service Dealer. 18. Clean, adjust or replace spark plug. 19. Check the spark plug wire connection. 20. Replace module.
Engine loses power	1. Fuel level is low. 2. Engine load is excessive 3. Air cleaner is dirty. 4. Oil level in the crankcase is low. 5. Cooling fins and air passages for the engine are plugged.	1. Replace the LPG fuel tank. 2. Reduce the ground speed. 3. Clean or replace the air cleaner element. 4. Add oil to the crankcase. 5. Remove the obstructions from the cooling fins and air passages.
Engine overheats.	1. Engine load is excessive. 2. Oil level in the crankcase is low. 3. Cooling fins and air passages for the engine are plugged.	1. Reduce the ground speed. 2. Add oil to the crankcase. 3. Remove the obstructions from the cooling fins and air passages.
Mower pulls left or right (with levers fully forward)	1. Tire pressure in drive tires not correct.	1. Adjust tire pressure in the drive tires.
Machine does not drive	1. Drive release handle not in "operating" position. 2. Drive or pump belt is worn, loose or broken. 3. Drive or pump belt is off a pulley. 4. Broken or missing idler spring. 5. Hydraulic fluid level is low or too hot.	1. Position handle in "operating" position; see Drive Wheel Release Valves section in Operation. 2. Change the belt. 3. Change the belt. 4. Replace the spring. 5. Add hydraulic fluid to reservoir or let it cool down.
Uneven cutting height.	1. Blade(s) not sharp. 2. Cutting blade(s) is/are bent. 3. Mower deck is not level. 4. Underside of mower is dirty. 5. Tire pressure in drive tires not correct. 6. Blade spindle bent. 7. Tips of adjacent blades are at an uneven cutting height. Blades tips should be even within 3/16 inch which is approximately one blade thickness.	1. Sharpen the blade(s). 2. Install new cutting blade(s). 3. Level mower deck from side-to-side and front-to-rear. 4. Clean the underside of the mower. 5. Adjust tire pressure in the drive tires. 6. Contact an Authorized Service Dealer. 7. Replace blades, spindles and (or) check for damage to mower deck.
Abnormal vibration	1. Cutting blade(s) is/are bent or unbalanced. 2. Blade mounting bolt is loose. 3. Engine mounting bolts are loose. 4. Loose engine pulley, idler pulley, or blade pulley. 5. Engine pulley is damaged. 6. Blade spindle is bent.	1. Install new cutting blade(s). 2. Tighten the blade mounting bolt. 3. Tighten the engine mounting bolts. 4. Tighten the appropriate pulley. 5. Contact an Authorized Service Dealer. 6. Contact an Authorized Service Dealer.

Troubleshooting

Problem	Possible Cause	Corrective Action
Blades do not rotate.	<ol style="list-style-type: none">1. Drive belt is worn, loose or broken.2. Deck belt is worn, loose or broken.3. Deck belt is off pulley.4. Broken or missing idler spring.5. Drive belt not routed correctly.	<ol style="list-style-type: none">1. Check the belt tension.2. Install new deck belt.3. Install belt on clutch and deck pulleys, idlers, and tensioning idler per routing decal on deck.4. Replace the spring.5. Refer to belt routing decal on deck.
Clutch will not engage.	<ol style="list-style-type: none">1. Fuse is blown.2. Low voltage supply at the clutch.3. Damaged coil.4. Inadequate current supply.5. Rotor/armature airgap is too large.	<ol style="list-style-type: none">1. Replace fuse. Check coil resistance, battery charge, charging system, and wiring connections and replace if necessary.2. Check coil resistance, battery charge, charging system, and wiring connections and replace if necessary.3. Replace clutch.4. Repair or replace clutch lead wire or electrical system. Clean connector contacts.5. Remove shim or replace clutch.

Schematics

Electrical Diagram

Main Electrical Diagram

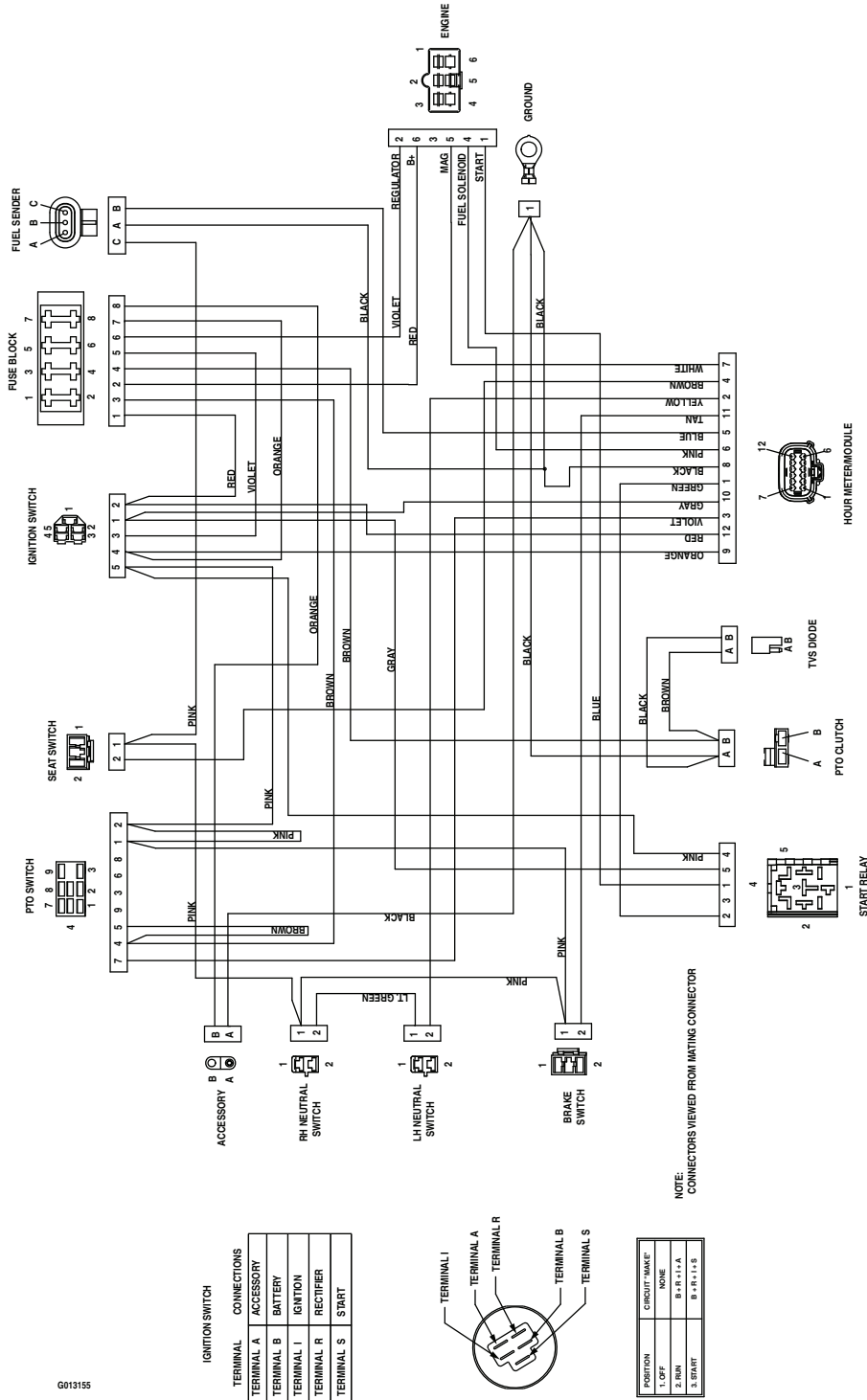

LPG Electrical Diagram

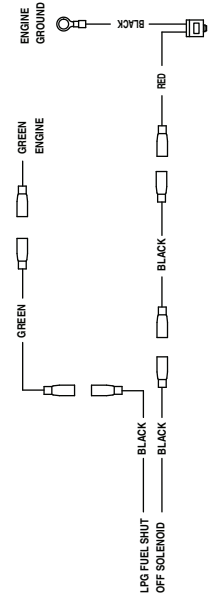

G013155

Electrical Logic Schematic

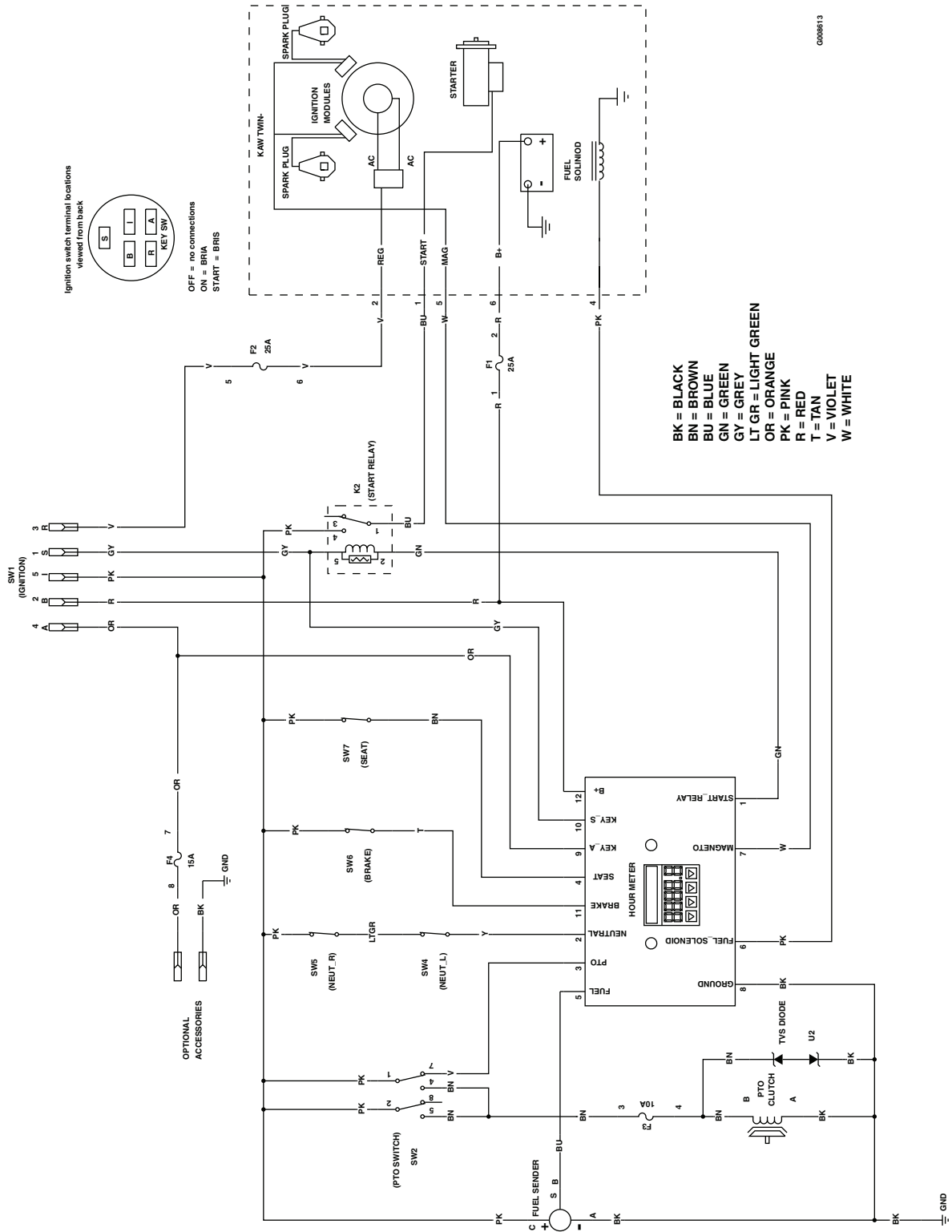

0006513

Hydraulic Diagram

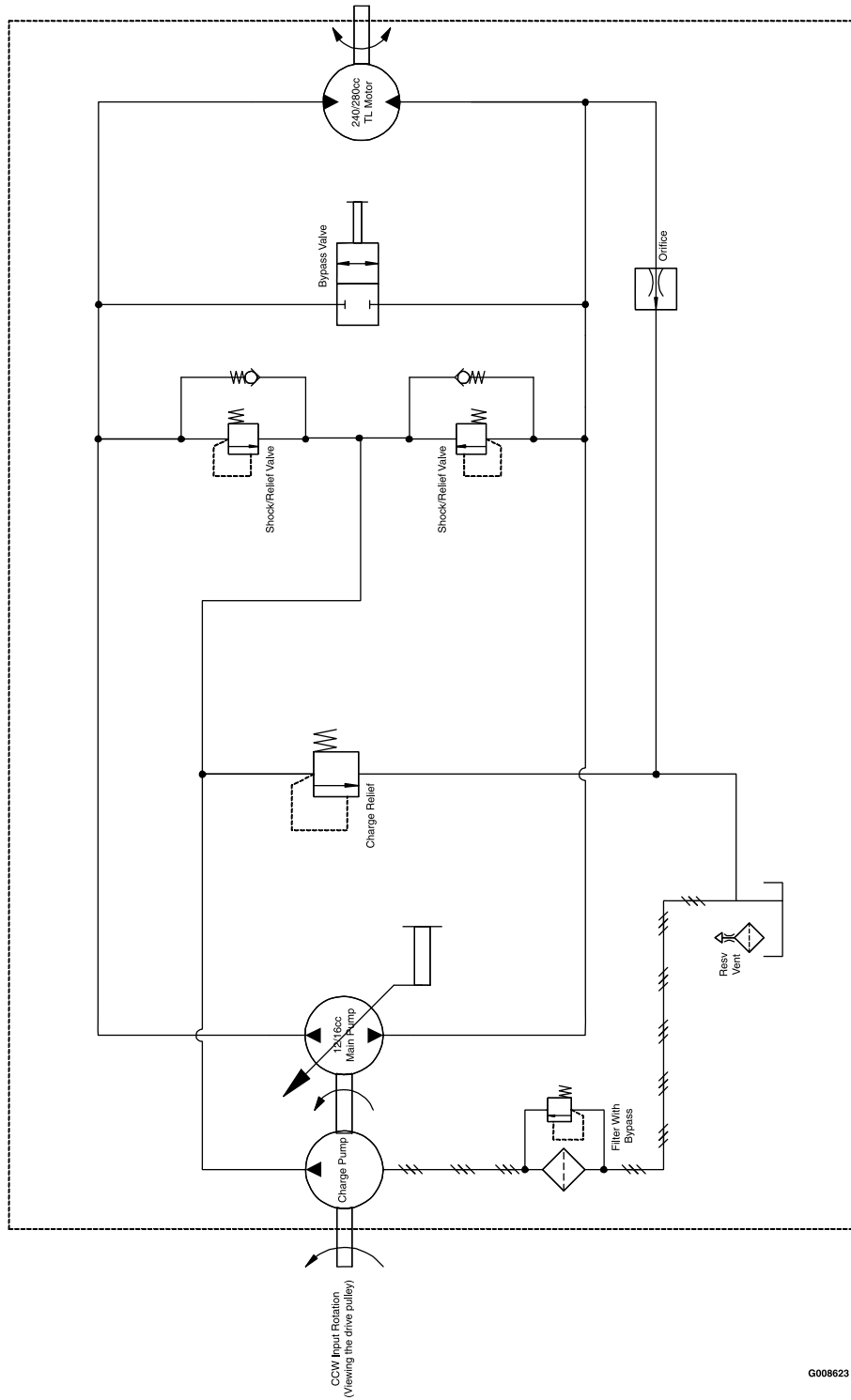

G008623

Exmark Lazer Z, Lazer Z Advantage Series X, and Vantage Turf Equipment 3 Year Limited Commercial Warranty 5 Year or 750 Hours Limited Consumer Warranty

General Warranty Conditions and Products Covered

Exmark Mfg. Co. Inc. and its affiliate, Exmark Warranty Company, pursuant to an agreement between them, jointly warrant on the terms and conditions herein, that we will repair, replace or adjust any part on these products and found by us (in the exercise of our reasonable discretion) to be defective in factory materials or workmanship.

This warranty may only be assigned or transferred to a second (or third) owner by an authorized Exmark dealer. The warranty period commences upon the date of the original retail purchase.

Commercial Warranty Conditions

This warranty applies to Exmark Lazer Z, Lazer Z Advantage Series (AS) X, and Vantage turf equipment sold in the U.S. or Canada for a period of three years for commercial usage.

This warranty includes the cost of parts and labor for a period of two years and the cost of parts for one additional year. This warranty does not cover pickup and delivery charges to and from any authorized Exmark Service Dealer.

Consumer Warranty Conditions

This warranty applies to Exmark Lazer Z, Lazer Z AS X, and Vantage turf equipment sold in the U.S. or Canada for a period of five years or 750 hours (whichever occurs first) for residential usage.

Residential usage means use of the product on the same lot as your home. Use at more than one location is considered commercial use, and the commercial use warranty detailed above would apply.

This warranty only includes the cost of parts and labor. For the first warrantable service repair, Exmark will cover up to \$45 for associated pick-up and delivery charges to and from any authorized Exmark Service Dealer. Additional transportation charges may apply, contact your Dealer for details.

Warranty Exceptions

<u>Warranty Exceptions</u>	<u>Warranty Period</u>
• Bags, Belts and Tires	90 days
• Battery	1 Year Prorated
• Engine (except Kohler EFI)	2 years*
• Kohler EFI Engine	3 years*

* The Engine warranty is covered by the engine manufacturer. Please refer to the engine manufacturer's warranty statement that is included in the literature packet.

Items and Conditions Not Covered

This warranty does not cover the following:

- Any damage or deterioration due to normal use, wear and tear, or exposure.
- Cost of regular maintenance service or parts, such as filters, fuel, lubricants, tune-up parts, and adjustments.
- Any product or part which has been altered or misused or required replacement or repair due to normal wear, accidents, or lack of proper maintenance.
- Any repairs necessary due to use of parts, accessories or supplies, including gasoline, oil or lubricants, incompatible with the turf equipment or other than as recommended in the operator's manual or other operational instructions provided by Exmark.

There are no other express warranties except for engine and special emission system coverage.

All warranty work must be performed by an authorized Exmark Service Dealer using Exmark approved replacement parts.

Instructions for Obtaining Warranty Service

The product must be registered with original proof of purchase by an Exmark Service Dealer before obtaining any warranty service.

Contact any Exmark Service Dealer to arrange service at their dealership. To locate a dealer convenient to you, access our website at www.exmark.com. U.S. or Canada customers may also call 402-223-6375.

If for any reason you are dissatisfied with the Service Dealer's analysis or with the assistance provided, contact us at:

Exmark Customer Service Department
The Exmark Warranty Company
2101 Ashland Avenue
Beatrice, NE 68310
402-223-6375 or
service@exmark.com

Owner's Responsibilities

If your product requires warranty service it must be returned to an authorized Exmark service dealer within the warranty period. This warranty extends only to turf equipment operated under normal conditions. You must read the operator's manual. You must also properly service and maintain your Exmark product as described in the operator's manual. Such routine maintenance, whether performed by a dealer or by you, is at your expense.

General Conditions

The sole liability of Exmark and Exmark Warranty Company with respect to this warranty shall be repair or replacement of defective components as set forth herein. **Neither Exmark nor Exmark Warranty Company shall be liable for any incidental or consequential loss or damage.**

Such damages include but are not limited to:

- Expenses related to gasoline, oil or lubricants.
- Travel time, overtime, after hours time or other extraordinary repair charges or charges relating to repairs or replacements outside of normal business hours at the place of business of the authorized Exmark Service Dealer.
- Rental of like or similar replacement equipment during the period of any warranty, repair or replacement work.
- Any telephone or telegram charges or travel charges.
- Loss or damage to person or property other than that covered by the terms of this warranty.
- Any claims for lost revenue, lost profit or additional cost as a result of a claim of breach of warranty.
- Attorney's fees.

No Claim of breach of warranty shall be cause for cancellation or rescission of the contract of sale of any Exmark mower.

All implied warranties of merchantability (that the product is fit for ordinary use) and fitness for use (that the product is fit for a particular purpose) are limited to the duration of the express warranty.

Some states do not allow exclusions of incidental or consequential damages, or limitations on how long an implied warranty lasts, so the above exclusions and limitations may not apply to you.

This warranty gives you specific legal rights, and you may also have other rights which vary from state to state.

G4500-590_C

Notes:

Service Record

Date:	Description of Work Done:	Service Done By:

NEW EXMARK PREMIUM HYDRO OIL

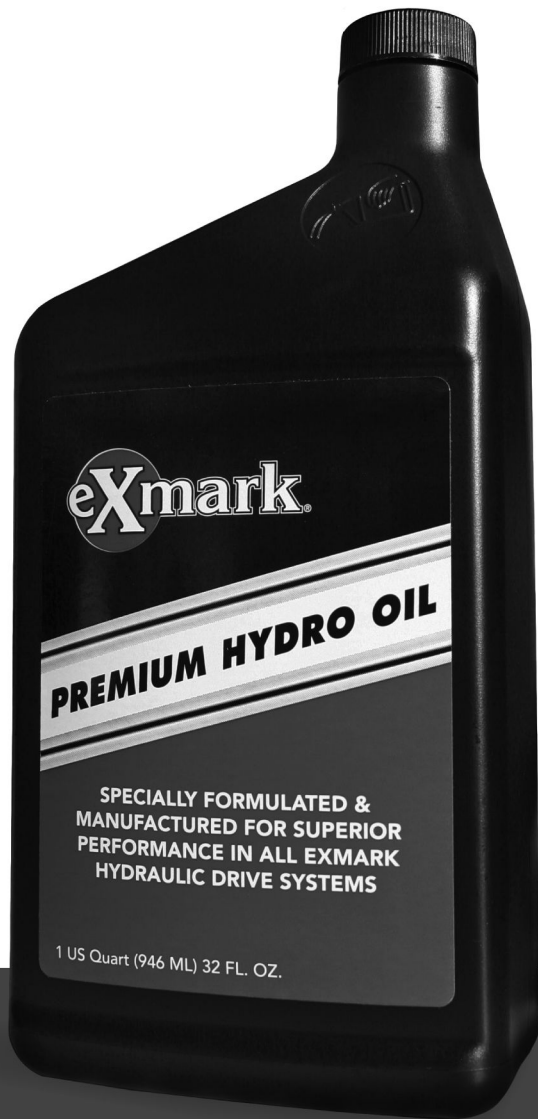

BENEFITS

- Designed & manufactured with superior anti-wear protection
- Superior thermal stability
- Consistent hydro performance
- Superior shear resistance under heavy loads
- Field tested & proven performance
- Twice the shear stability of competing oils
- Enhanced control performance
- Specially formulated for any Exmark hydraulic system

**NOW AVAILABLE
FOR PURCHASE**

Part No. 109-9828



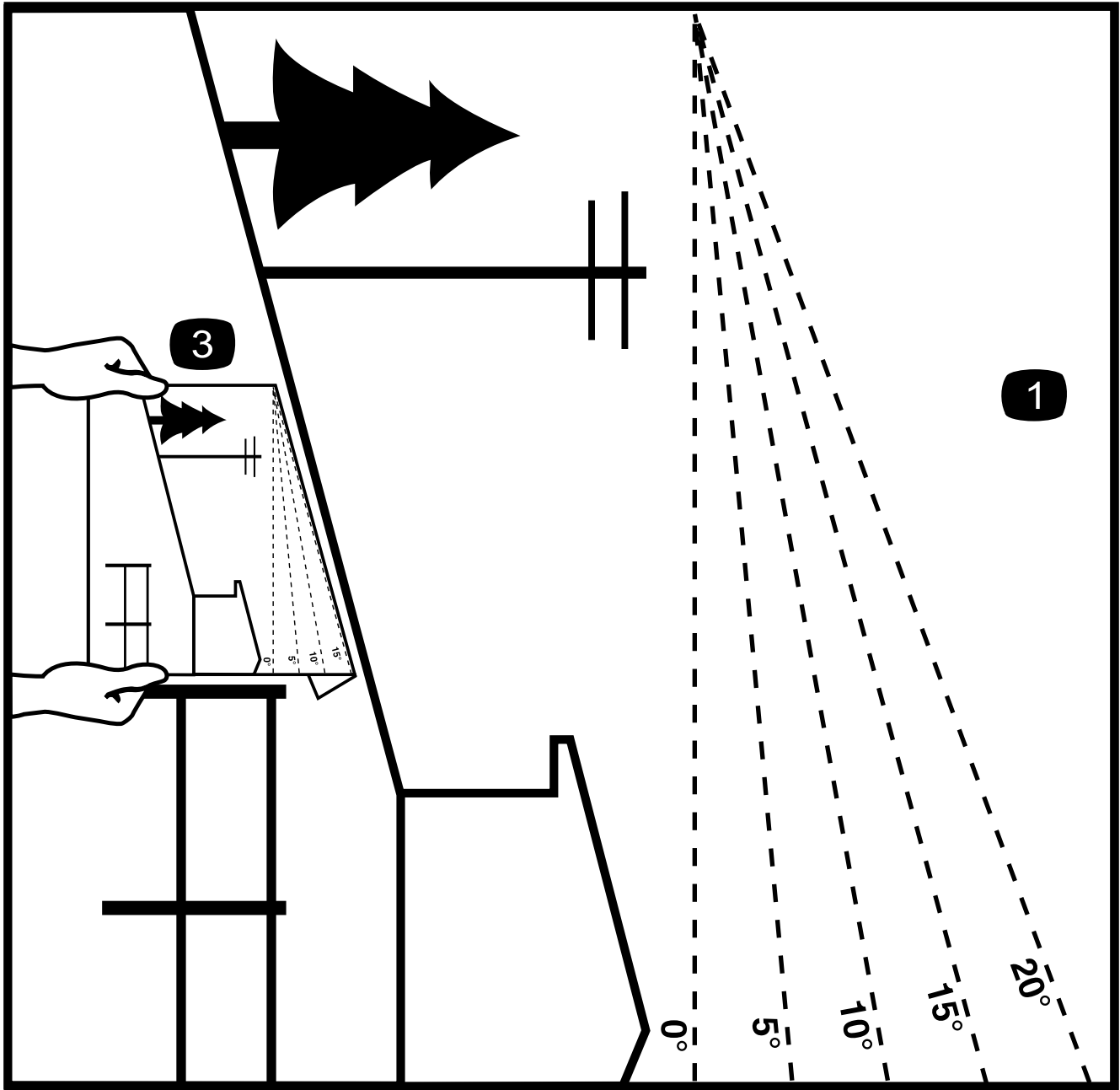

G011841

2

Figure 44

This page may be copied for personal use.

1. The maximum slope you can safely operate the machine on is **15 degrees**. Use the slope indicator to determine the degree of slope of hills before operating. **Do Not operate this machine on a slope greater than 15 degrees.** Fold along the appropriate line to match the recommended slope.
2. Align this edge with a vertical surface, a tree, building, fence pole, etc.
3. Example of how to compare slope with folded edge.

SEE EXMARK'S COMPLETE LINE OF ACCESSORIES AND OPTIONS

MID-MOUNT RIDING ACCESSORIES AND OPTIONS

CUSTOM RIDE SEAT SUSPENSION SYSTEM	OPERATOR CONTROLLED DISCHARGE
FULL SUSPENSION SEAT	ROLL OVER PROTECTION SYSTEM (ROPS)
DECK LIFT ASSIST KIT	SUN SHADE
HITCH KIT	TRASH CONTAINER
LIGHT KIT	TURF STRIPER
12V POWER PORT	ULTRA VAC COLLECTION SYSTEM
MICRO-MULCH SYSTEM	ULTRA VAC QUICK DISPOSAL SYSTEM

OUT-FRONT RIDING ACCESSORIES AND OPTIONS

CUSTOM RIDE SEAT SUSPENSION SYSTEM	SNOW BLADE
DUAL-TAIL WHEEL	SNOWBLOWER
FLOOR PAN EXTENDER	SUN SHADE
HITCH KIT	TRASH CONTAINER
LIGHT KIT	ULTRA VAC COLLECTION SYSTEM
MICRO-MULCH SYSTEM	ULTRA VAC QUICK DISPOSAL SYSTEM
ROLL OVER PROTECTION SYSTEM (ROPS)	WEATHER CAB

WALK-BEHIND ACCESSORIES AND OPTIONS

GRASS CATCHER	TURF STRIPER
MICRO-MULCH SYSTEM	STANDON

Place Model No. and Serial No.
Label Here (Included in the Literature
Pack) or Fill in Below

Model No. _____

Serial No. _____

Date Purchased _____

Engine Model No. and Spec. No. _____

Engine Serial No. (E/No) _____

© 2010 Exmark Mfg. Co., Inc.
Industrial Park Box 808
Beatrice, NE 68310
All Rights Reserved

Part No. 4500-645 Rev. A
(402) 223-6300
Fax (402) 223-5489
Printed in the USA

